

Hand-Powered Water Filter

Detail and Assembly

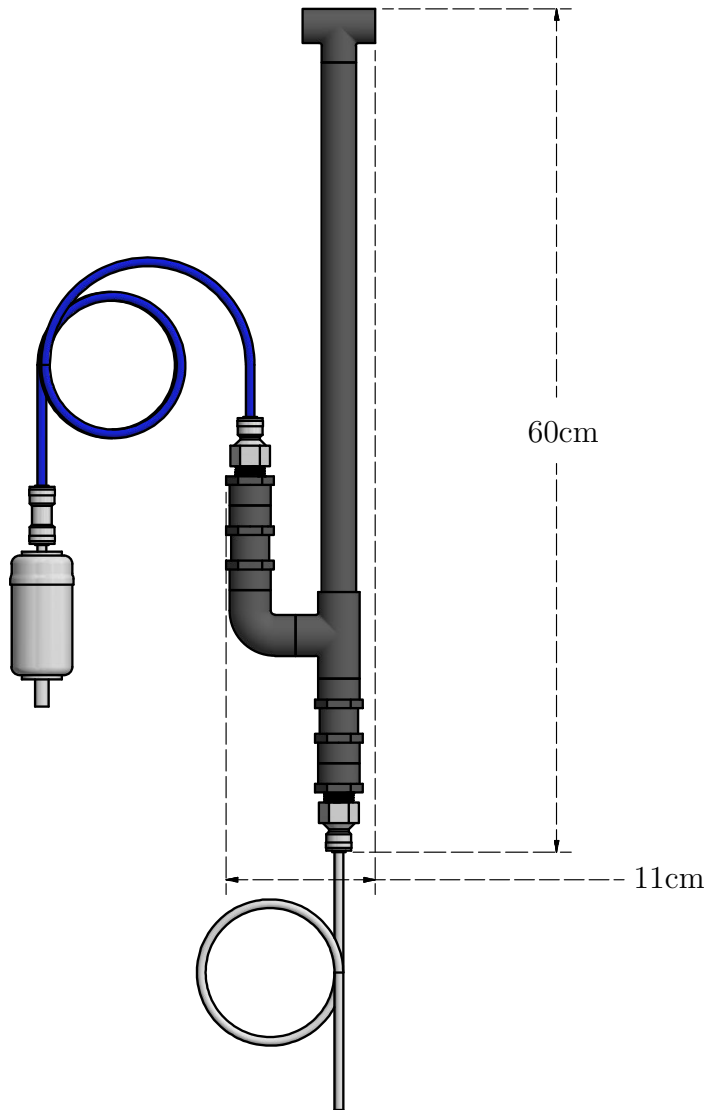

Version 5.00

Patent Pending

Last Updated January 5, 2018

Chris [REDACTED] Logston



Contents

- 1) Ultra Filter Detail 2
- 2) Check Valve Detail 3
- 3) Raw Parts List 4
- 4) Check Valve Assembly 7
- 5) Pump Assembly 13
- 6) Plunger Assembly 20

1) Ultra Filter Detail

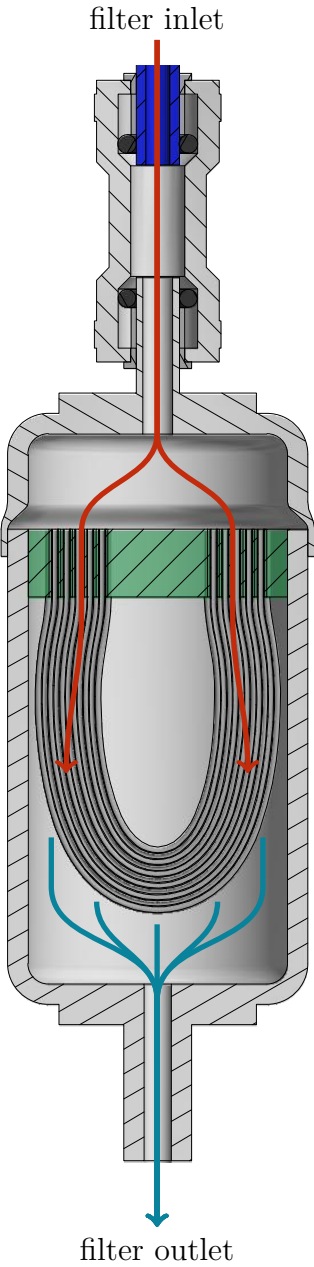

2) Check Valve Detail

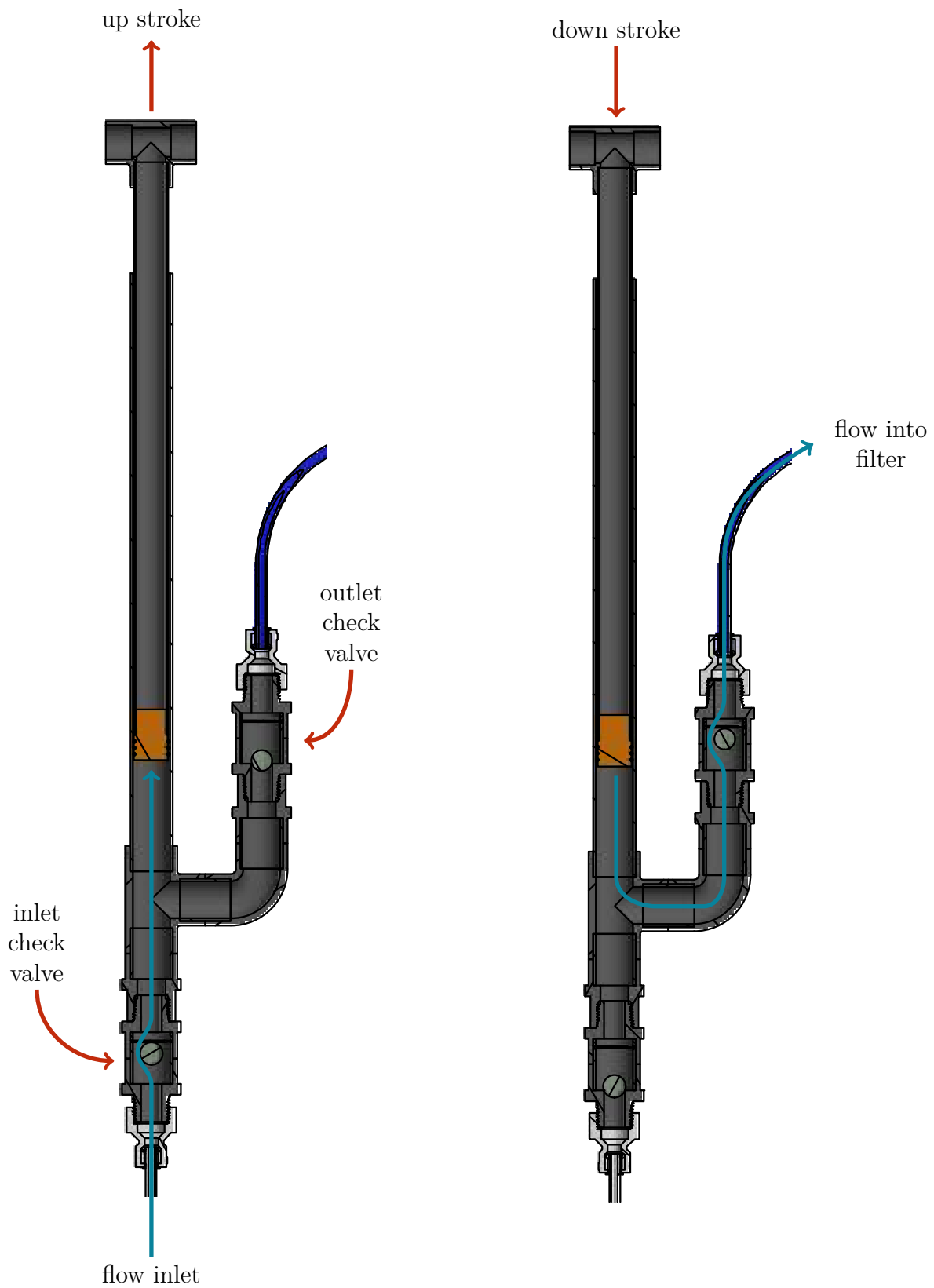

3) Raw Parts List

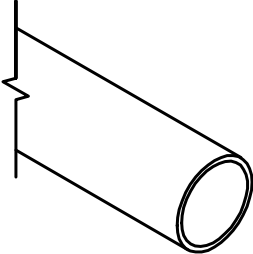
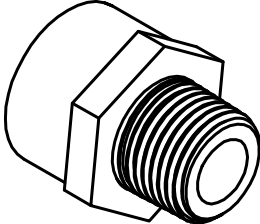
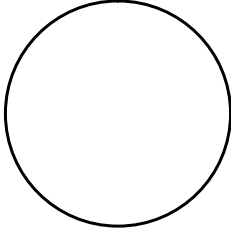
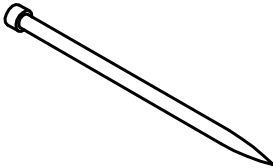
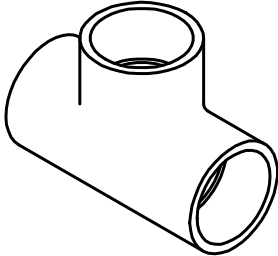
No.	Description	Image	QTY	PPU	TOT
A	PVC Pipe Piece, 25 mm diameter, 50 cm long		1	₹15	₹15
B	PVC Adapter, 25 mm plane female × 1/2" threaded male		4	₹10	₹40
C	Glass Marble, 1/2" diameter		2	₹2	₹4
D	Small Galvanized Nail, about 25 mm long		2	₹1	₹2
E	PVC Tee, 25 mm plane female × 25 mm plane female × 25 mm plane female		1	₹10	₹10

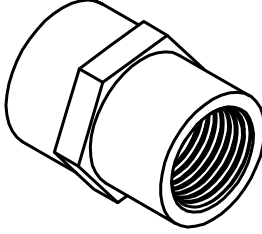
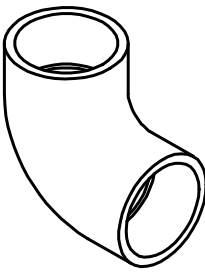
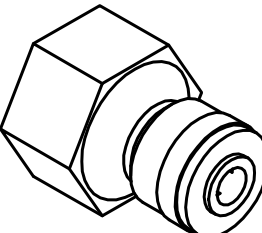
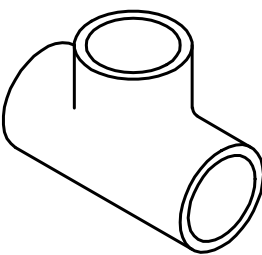
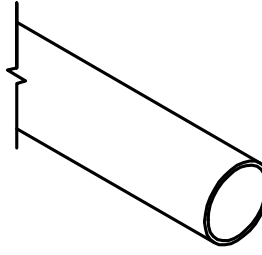
No.	Description	Image	QTY	PPU	TOT
F	PVC Adapting Coupling, 25 mm plane female × 1/2" threaded female		2	₹10	₹20
G	PVC Elbow, 25 mm plane female × 25 mm plane female		1	₹8	₹8
H	Quick Connect Fitting, 1/2" threaded female × 1/4" quick-connect female		2	₹45	₹90
I	PVC Tee, 20 mm plane female × 20 mm plane female × 20 mm plane female		1	₹8	₹8
J	PVC Pipe Piece, 20 mm diameter, 33 cm long		1	₹10	₹10

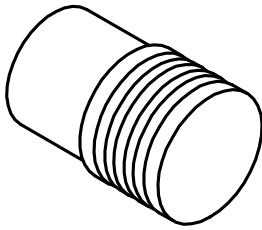
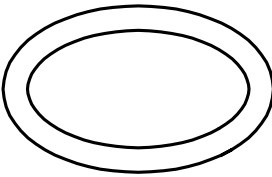
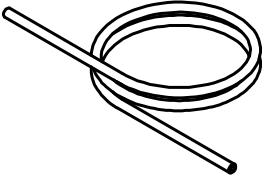
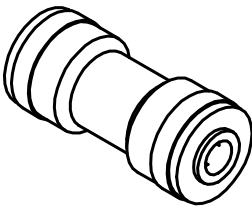
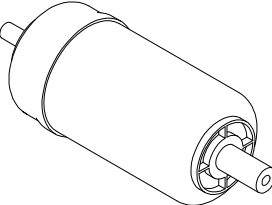
No.	Description	Image	QTY	PPU	TOT
K	PLA Chamber Plug		1	₹20	₹20
L	Plug O-ring		3	₹5	₹15
M	Quick Connect Tubing, 1/4" diameter, 50 cm long		2	₹7	₹14
N	Quick Connect Coupler, 1/4" quick-connect female × 1/4" quick-connect female		1	₹30	₹30
O	Ultrafilter		1	₹600	₹600
Device Total:					₹886

4) Check Valve Assembly

Step 01: Sand and cut six pieces from the 50 cm long, 25 mm PVC pipe piece.

P: 1 piece, 35 cm long

Q: 2 pieces, each 3 cm long

R: 3 pieces, each 3 cm long

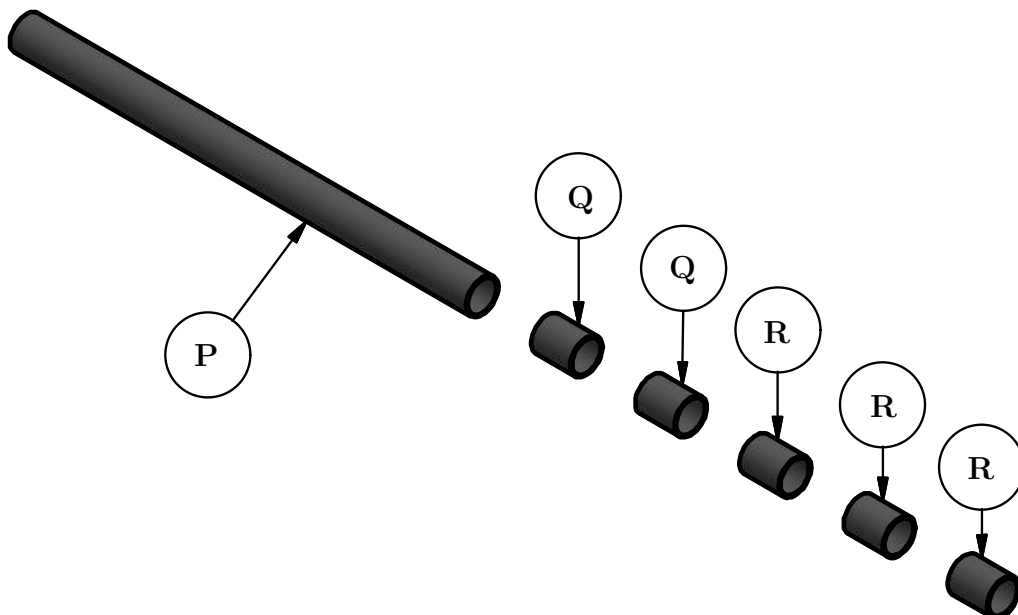
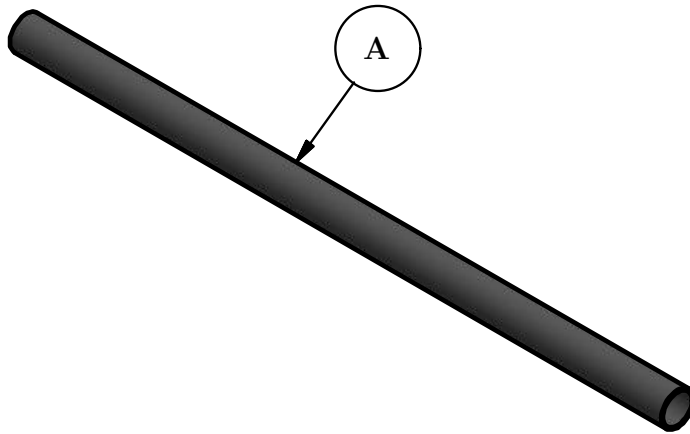

Step 02: Drill a small hole in two of the 30 cm long pipe pieces.

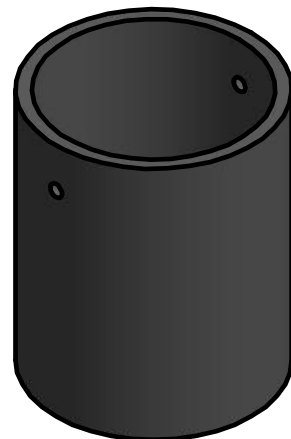
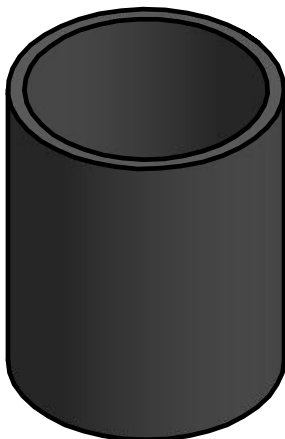
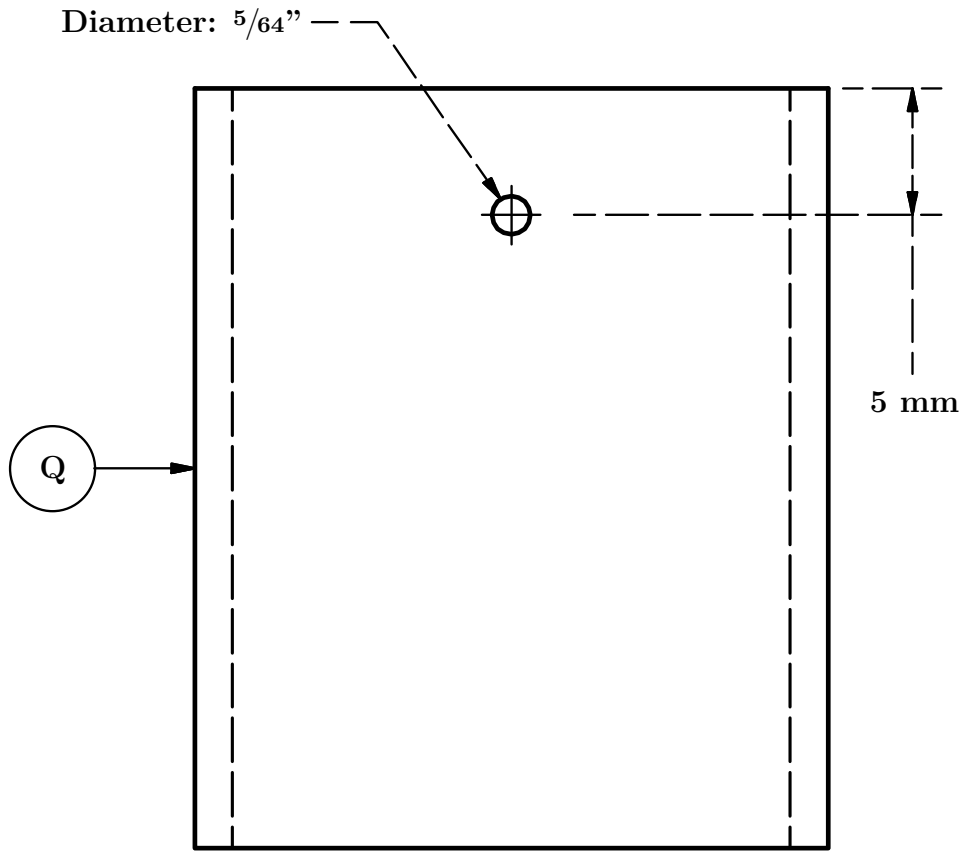

Step 03: Insert each drilled pipe piece into a PVC adapter.

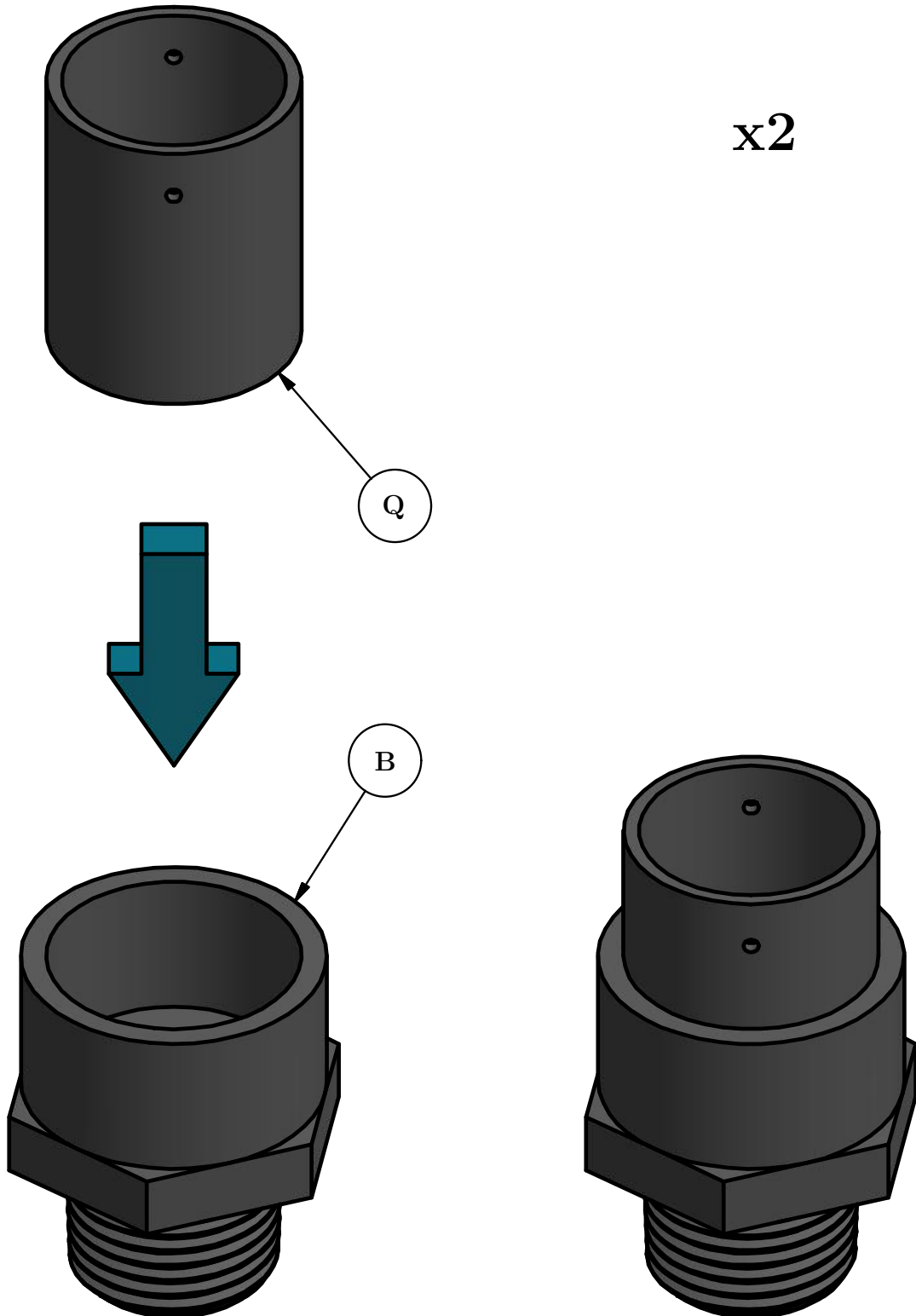

Step 04: Insert a pin into each drilled pipe piece.

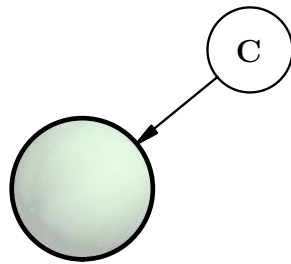

x2

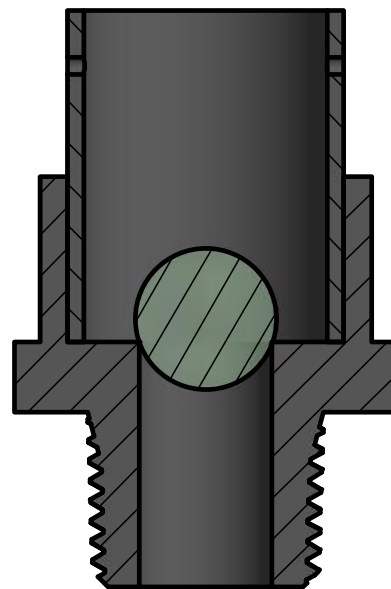
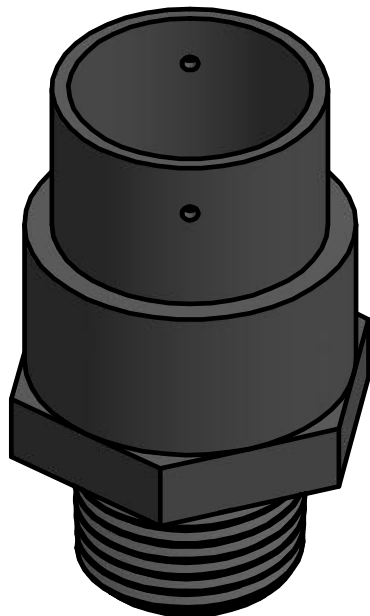
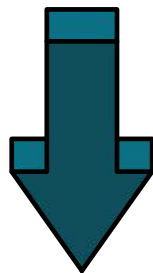

Step 05: Insert a marble into each drilled pipe piece.

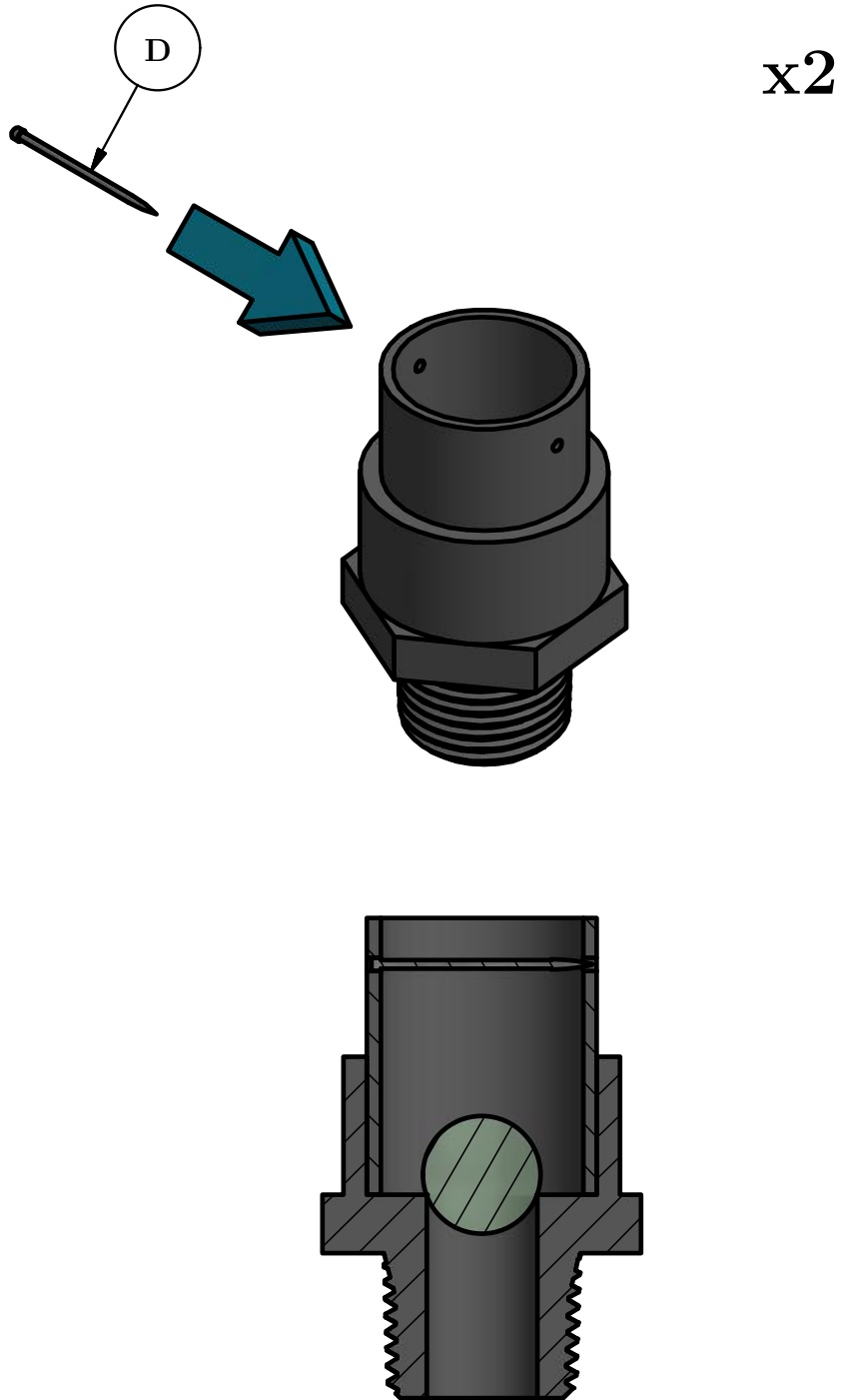

Step 06: Attach another PVC adapter to the other end of each drilled pipe piece.

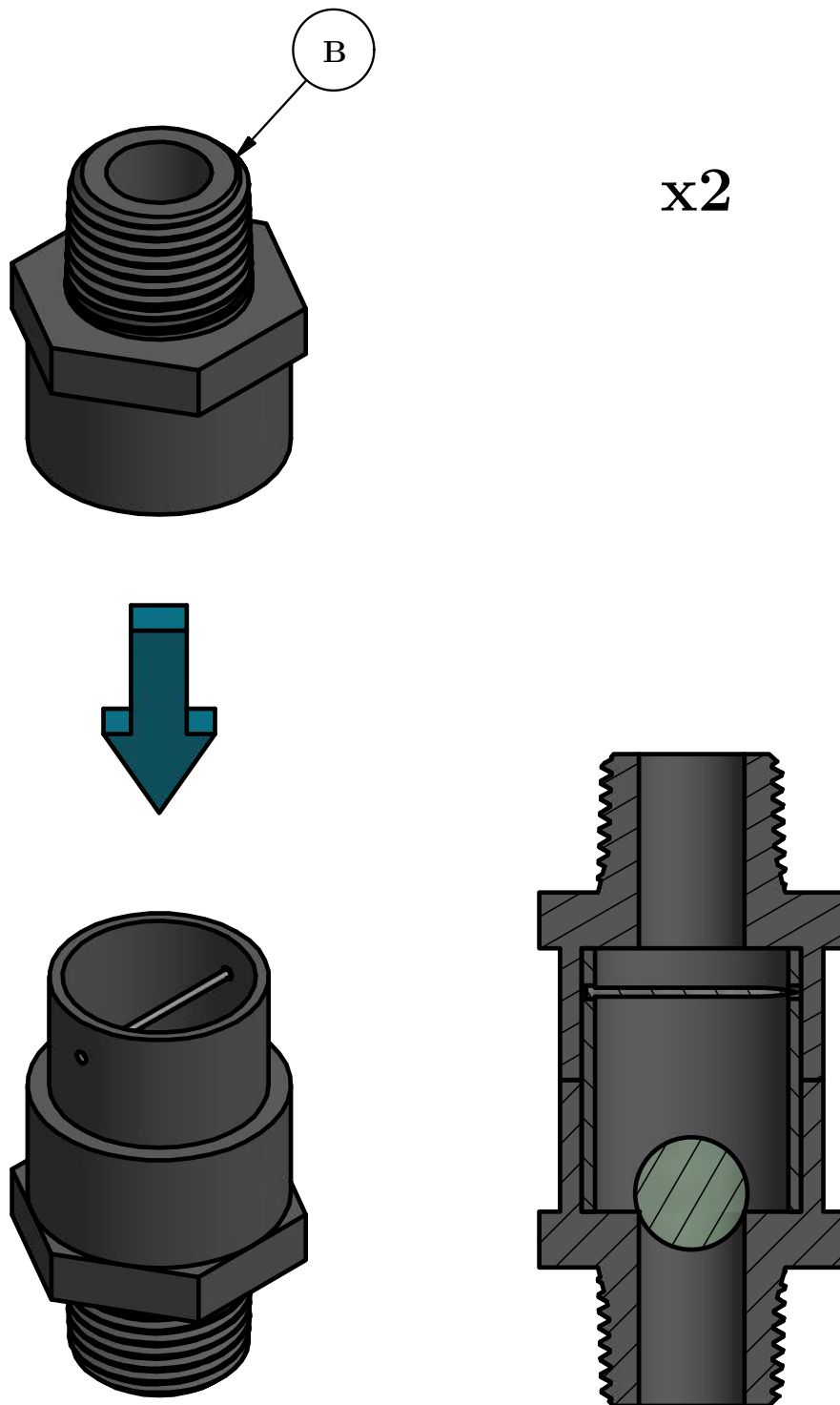

5) Pump Assembly

Step 07: Insert two of the remaining pipe pieces into two ends of the 25 mm PVC tee.

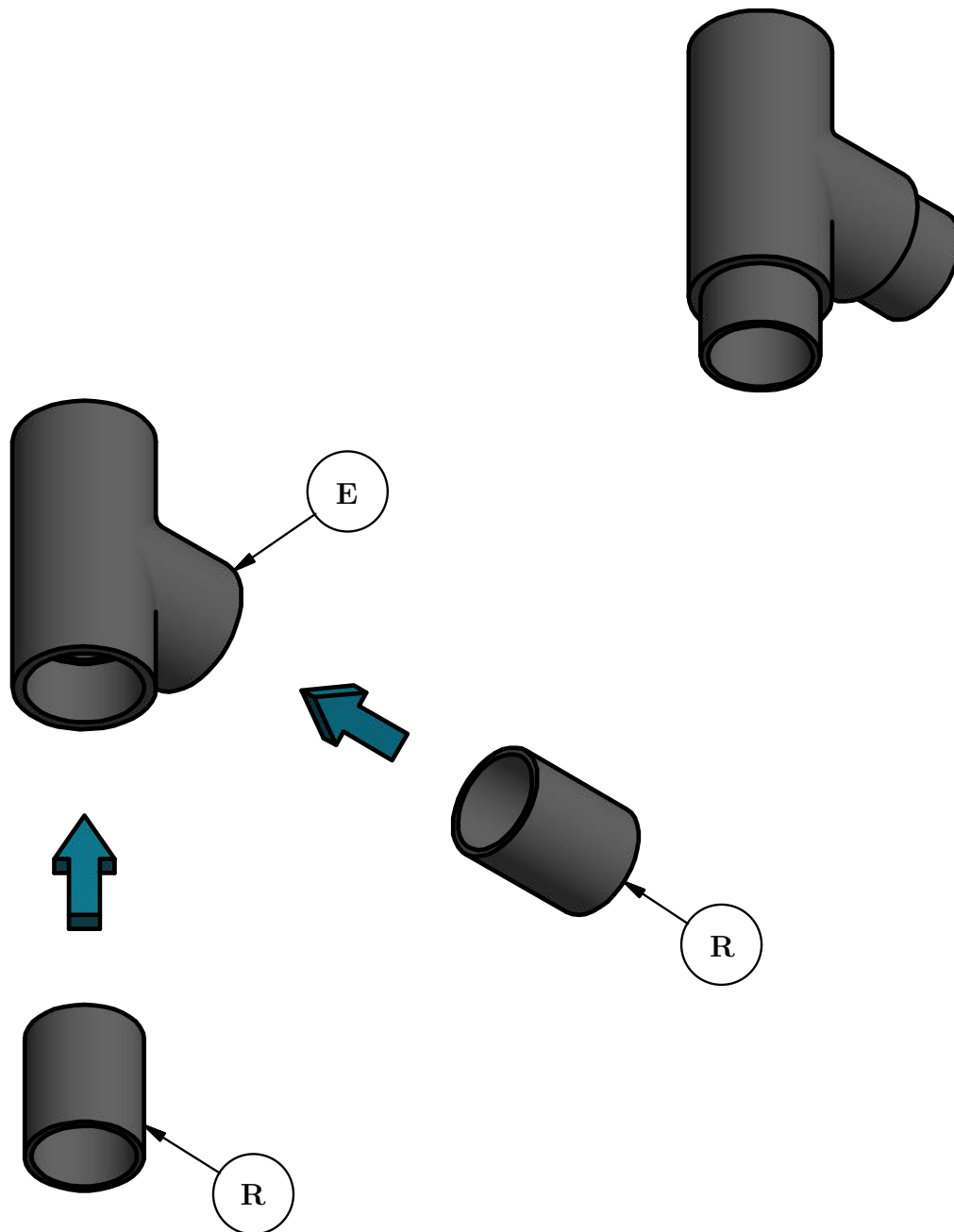

Step 08: Attach one of the adapting couplings to the bottom piece.

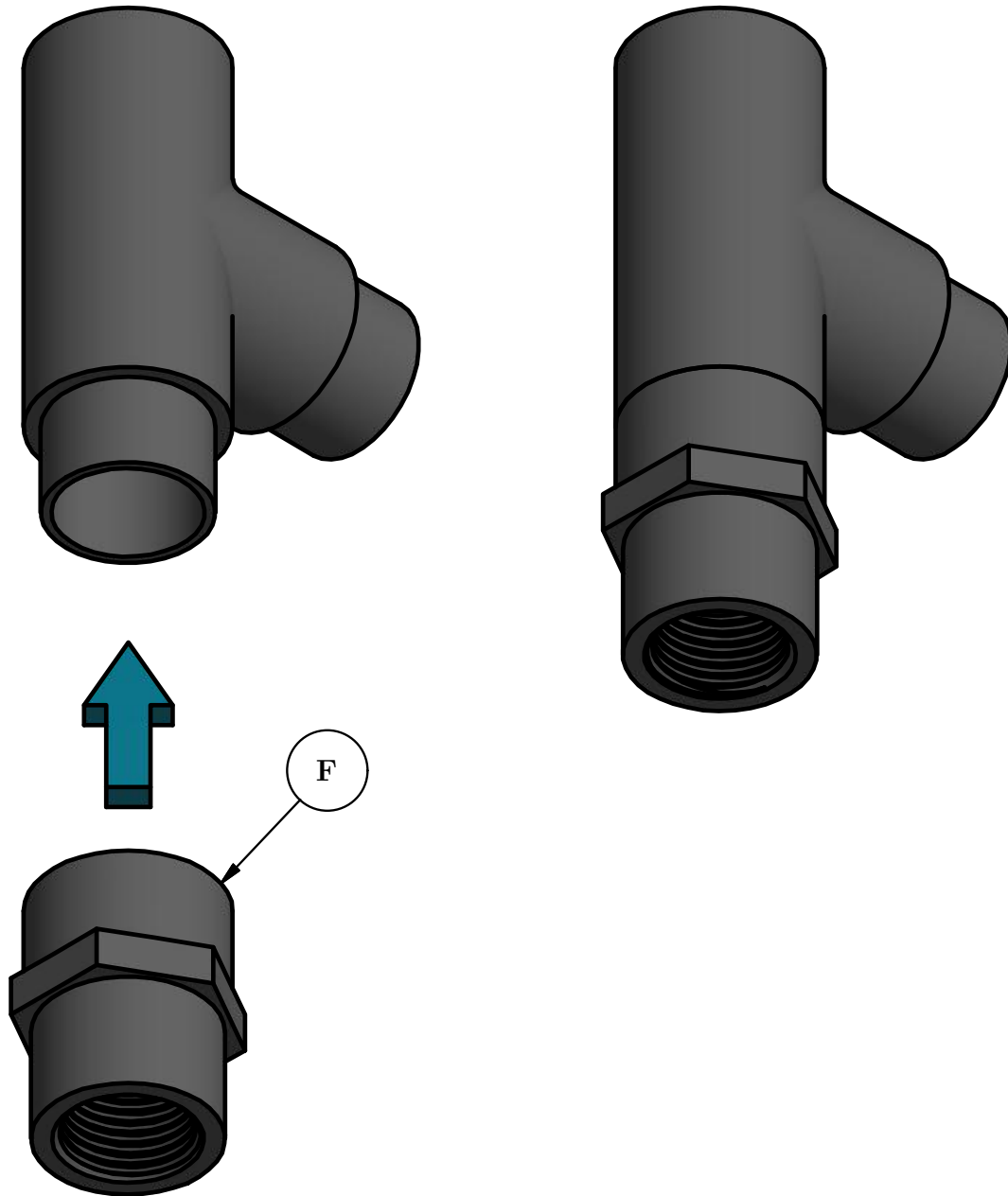

Step 09: Attach the elbow to the other pipe piece.

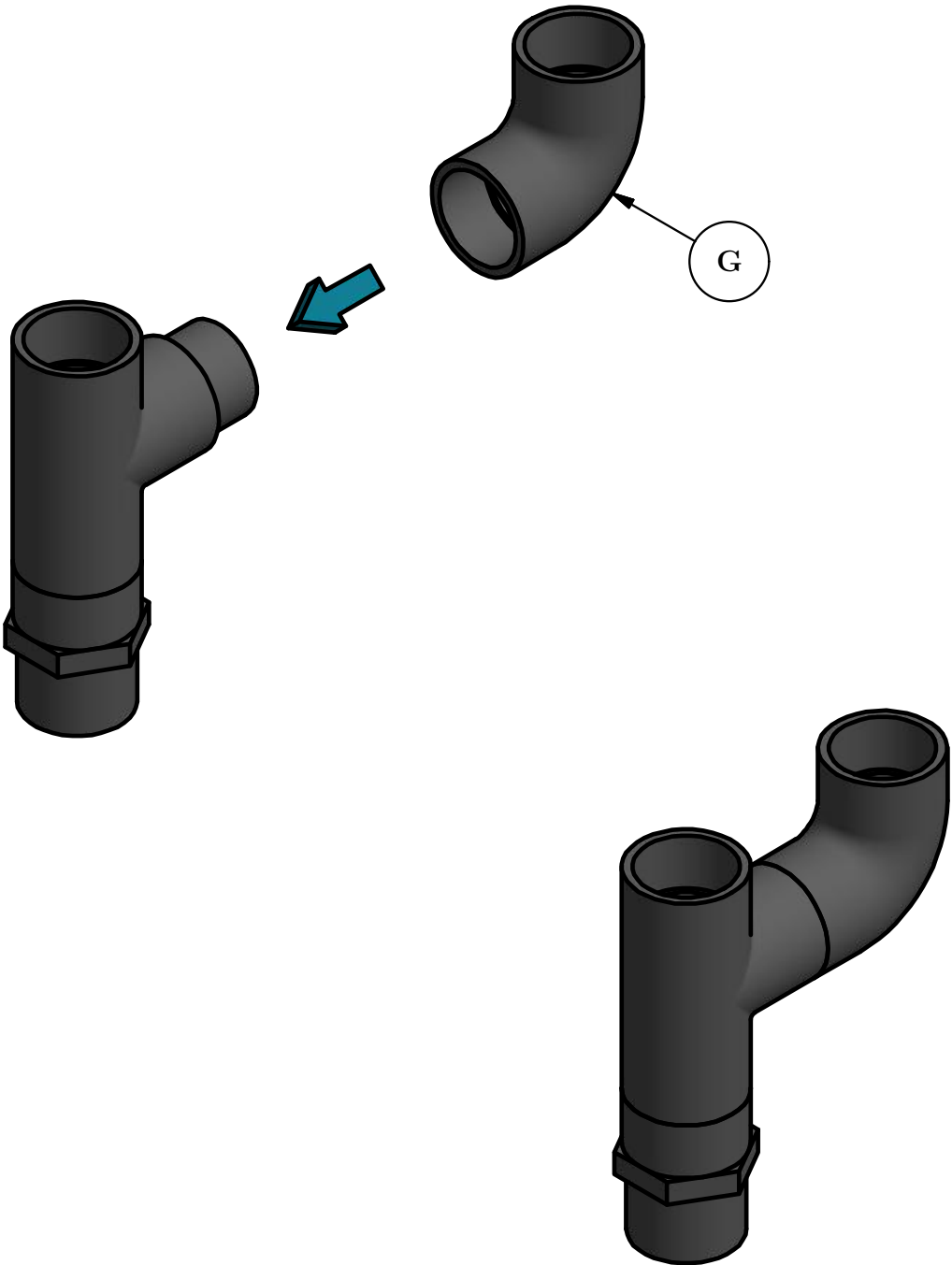

Step 10: Insert last undrilled pipe piece and adapting coupling into elbow.

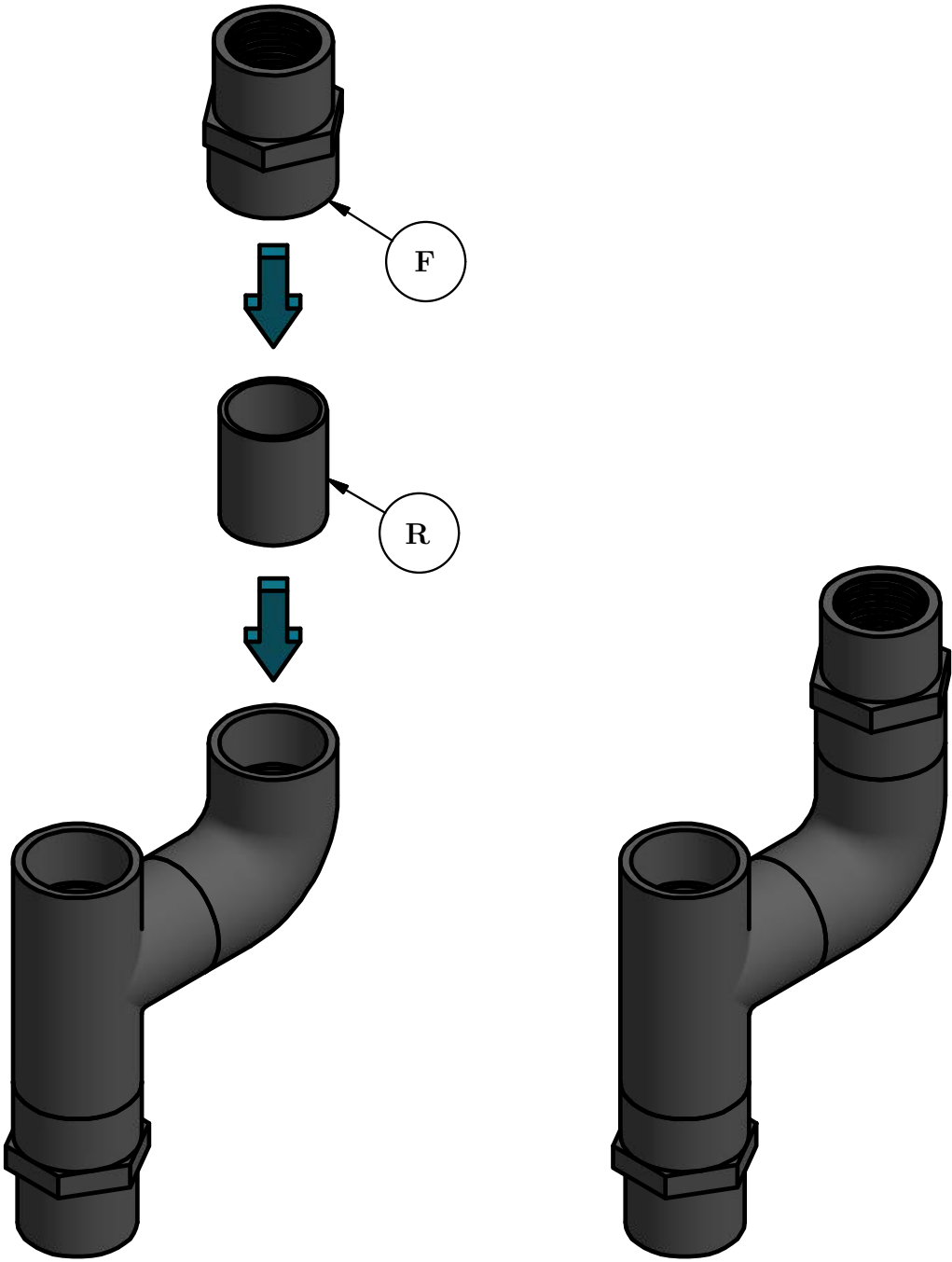

Step 11: Insert a check valve into the open end of each coupling adapter.

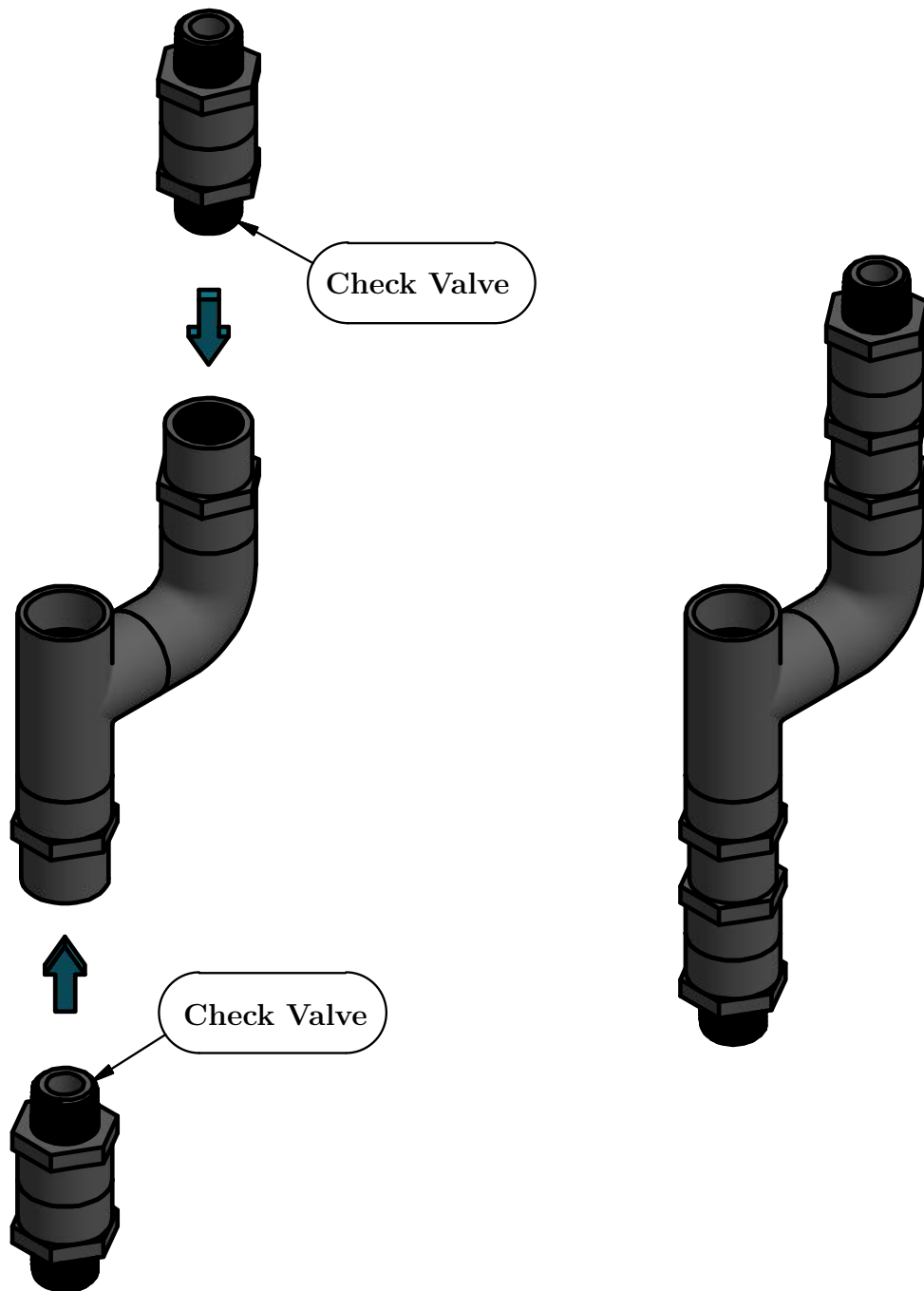

Step 12: Attach RO fitting to open end of each check valve.

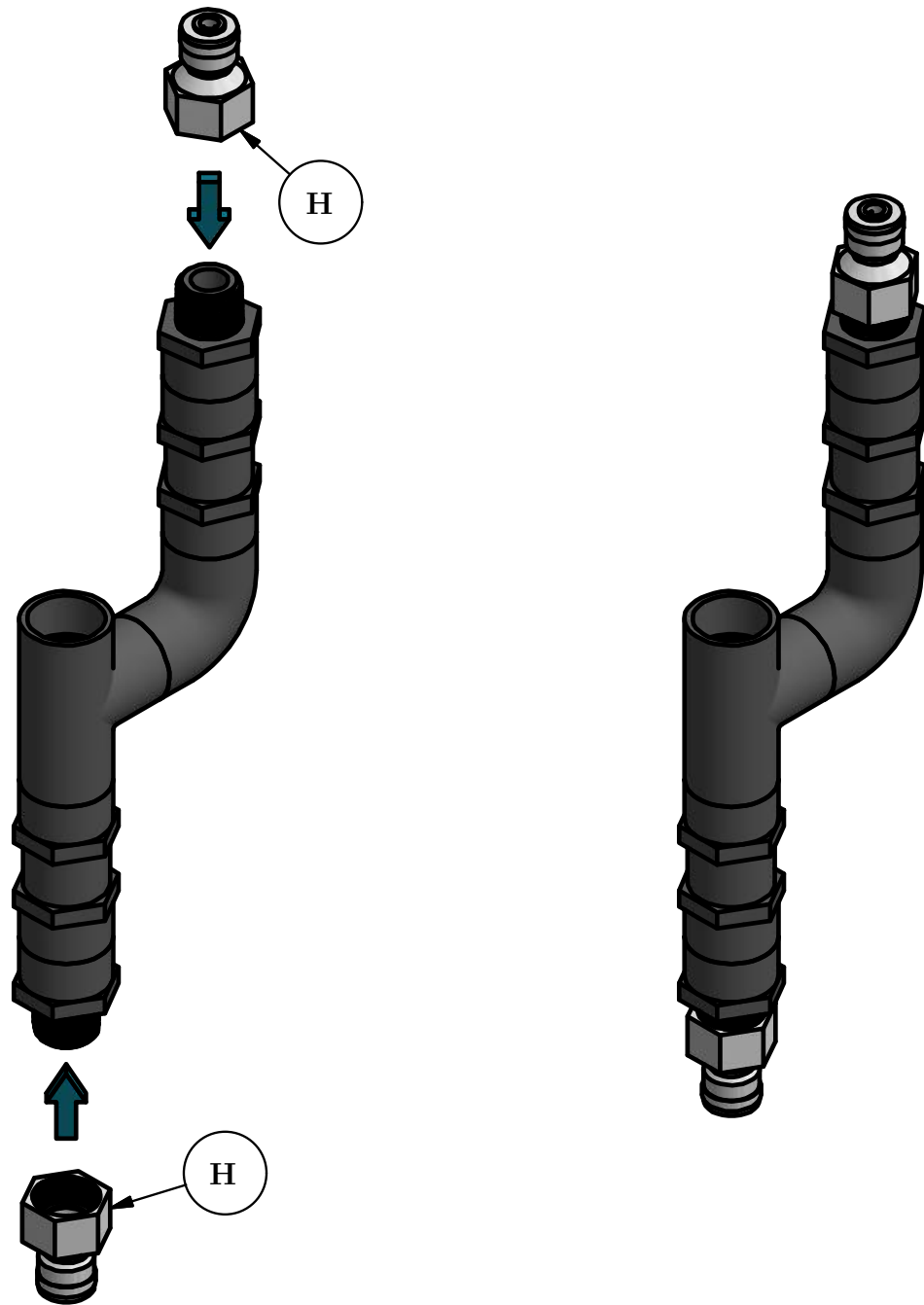

Step 13: Insert the longer 25 mm pipe piece into the tee's last open end.

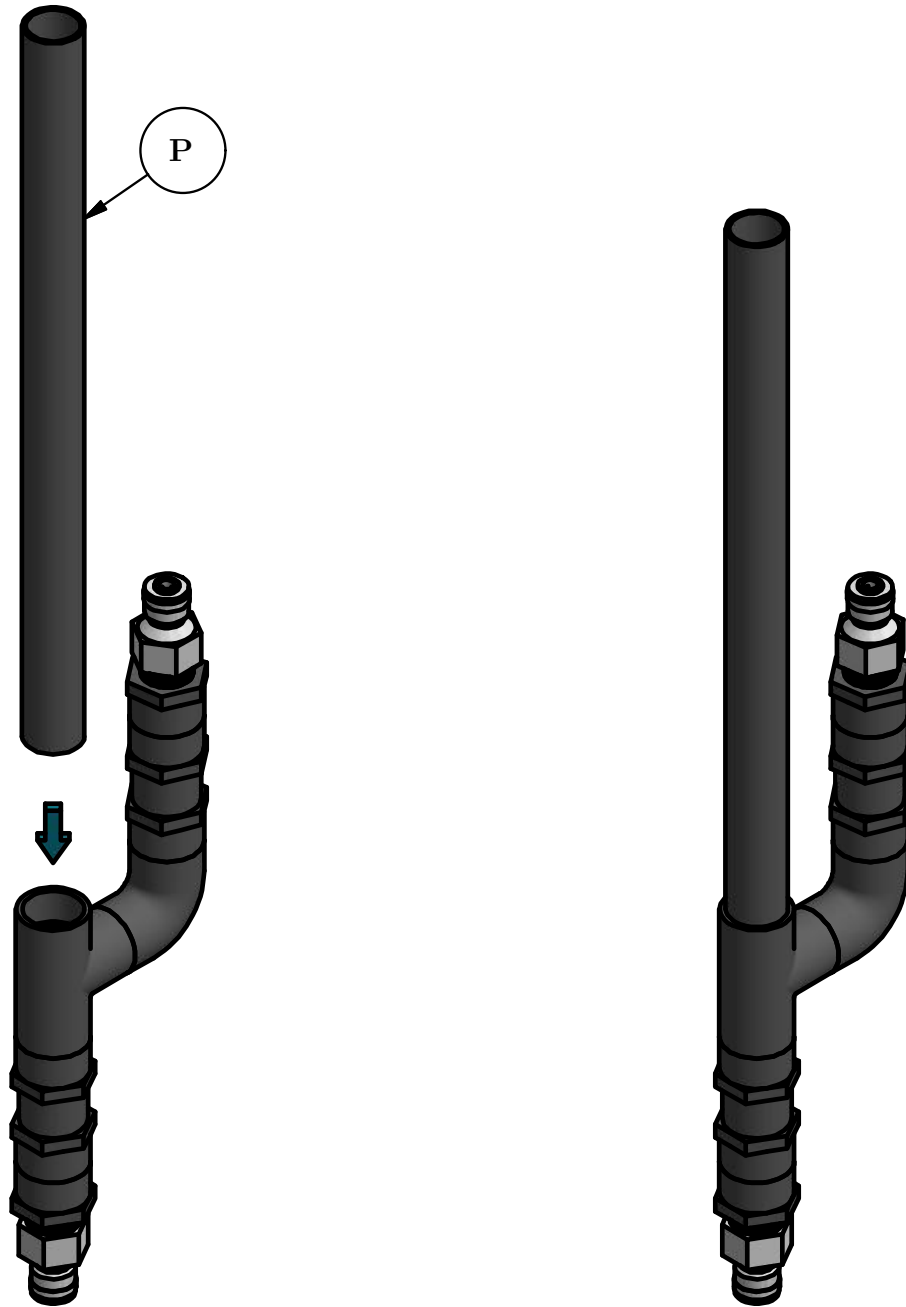

6) Plunger Assembly

Step 14: Attach the smaller tee to the smaller pipe.

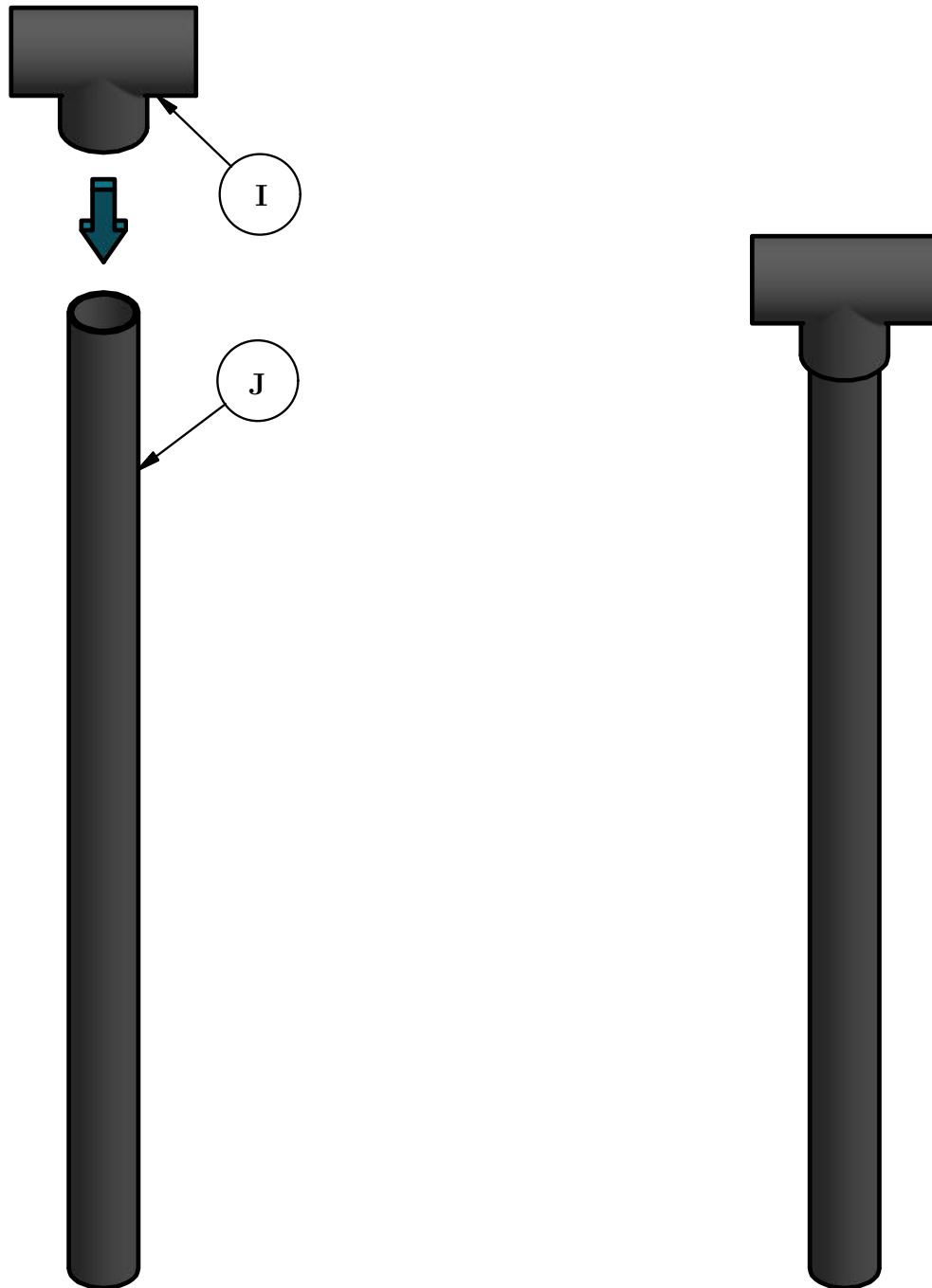

Step 15: Insert chamber plug into smaller pipe.

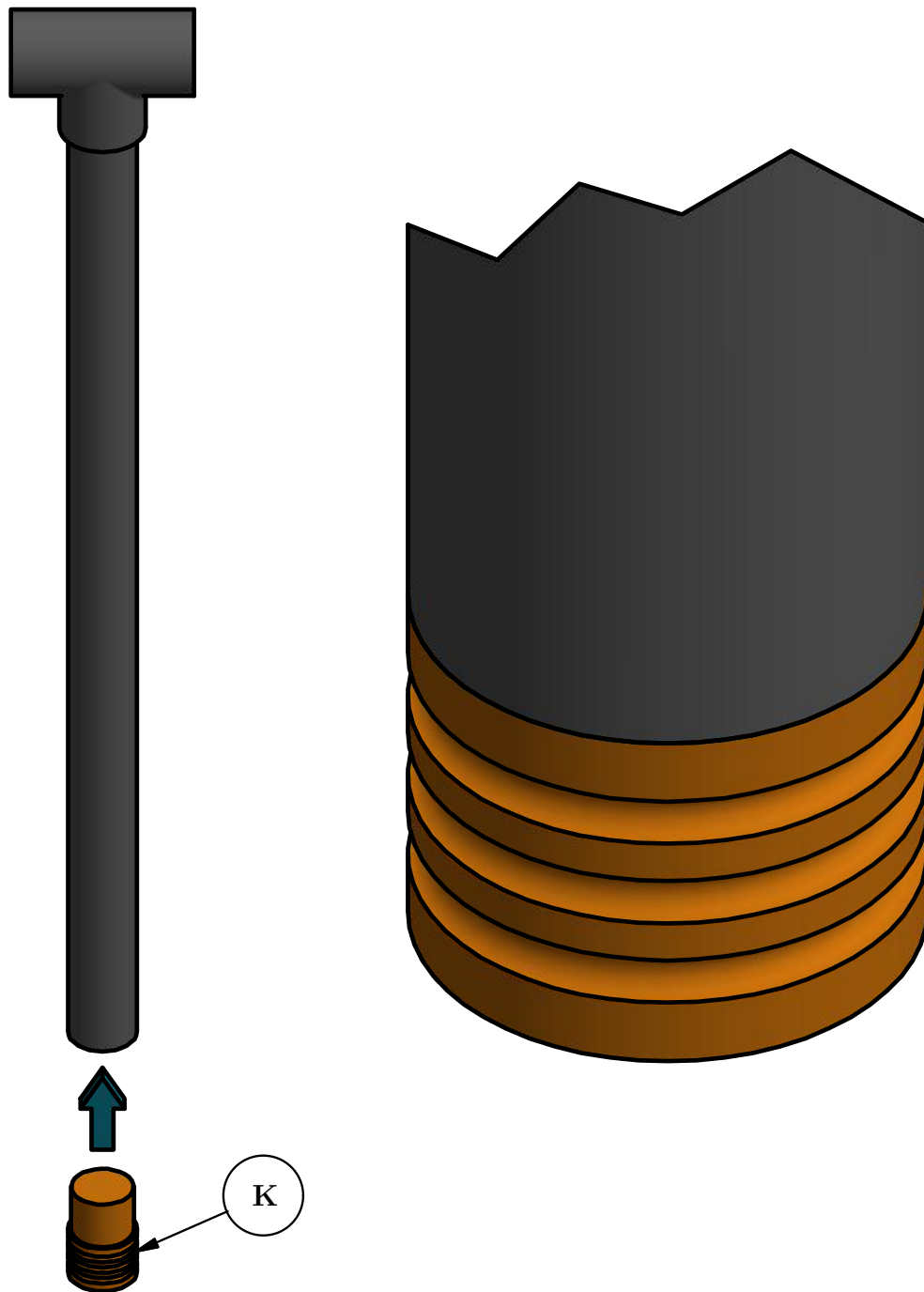

Step 16: Attach three O-rings to the plug.

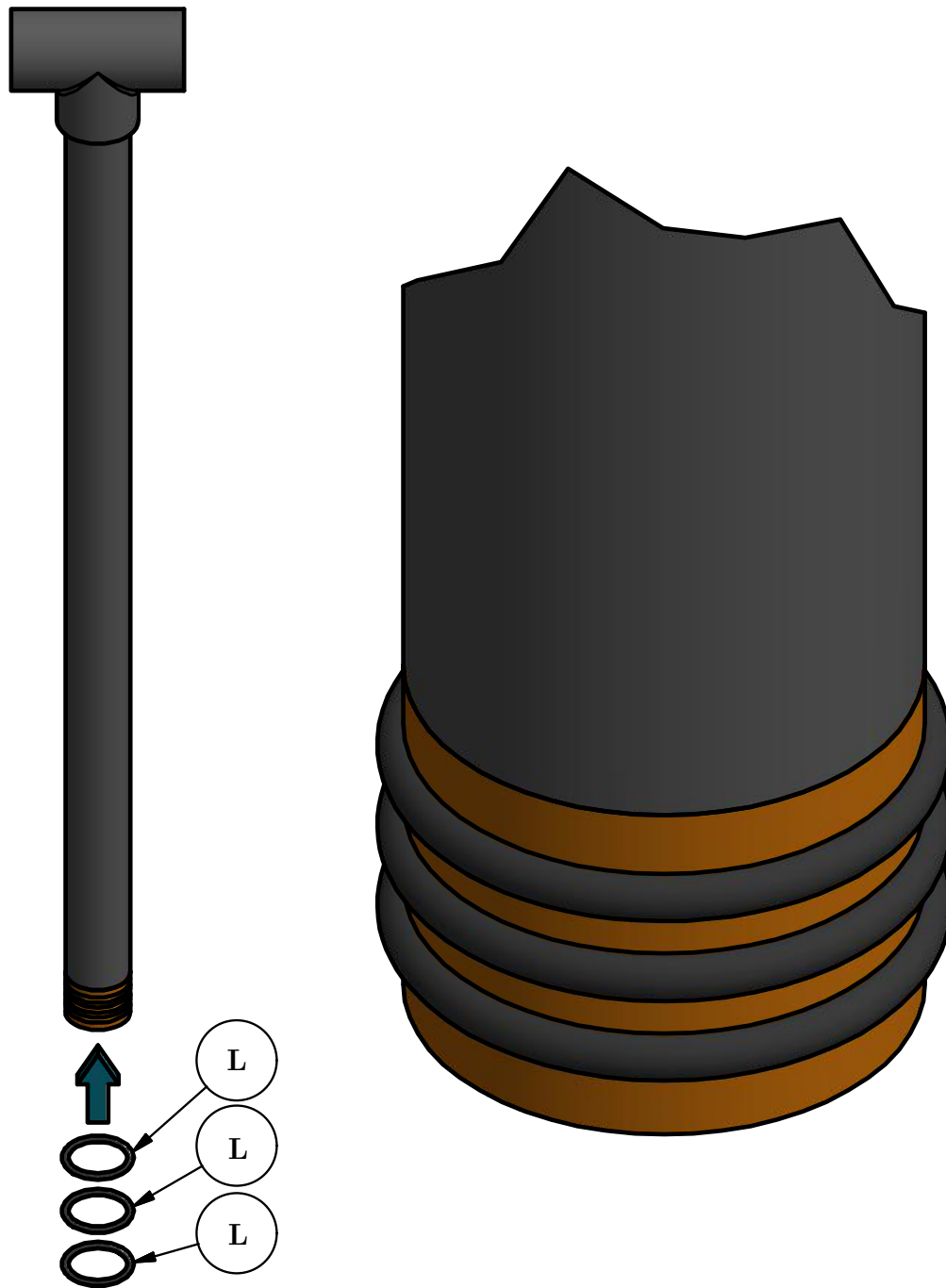

Step 17: Insert plunger assembly into pump assembly.

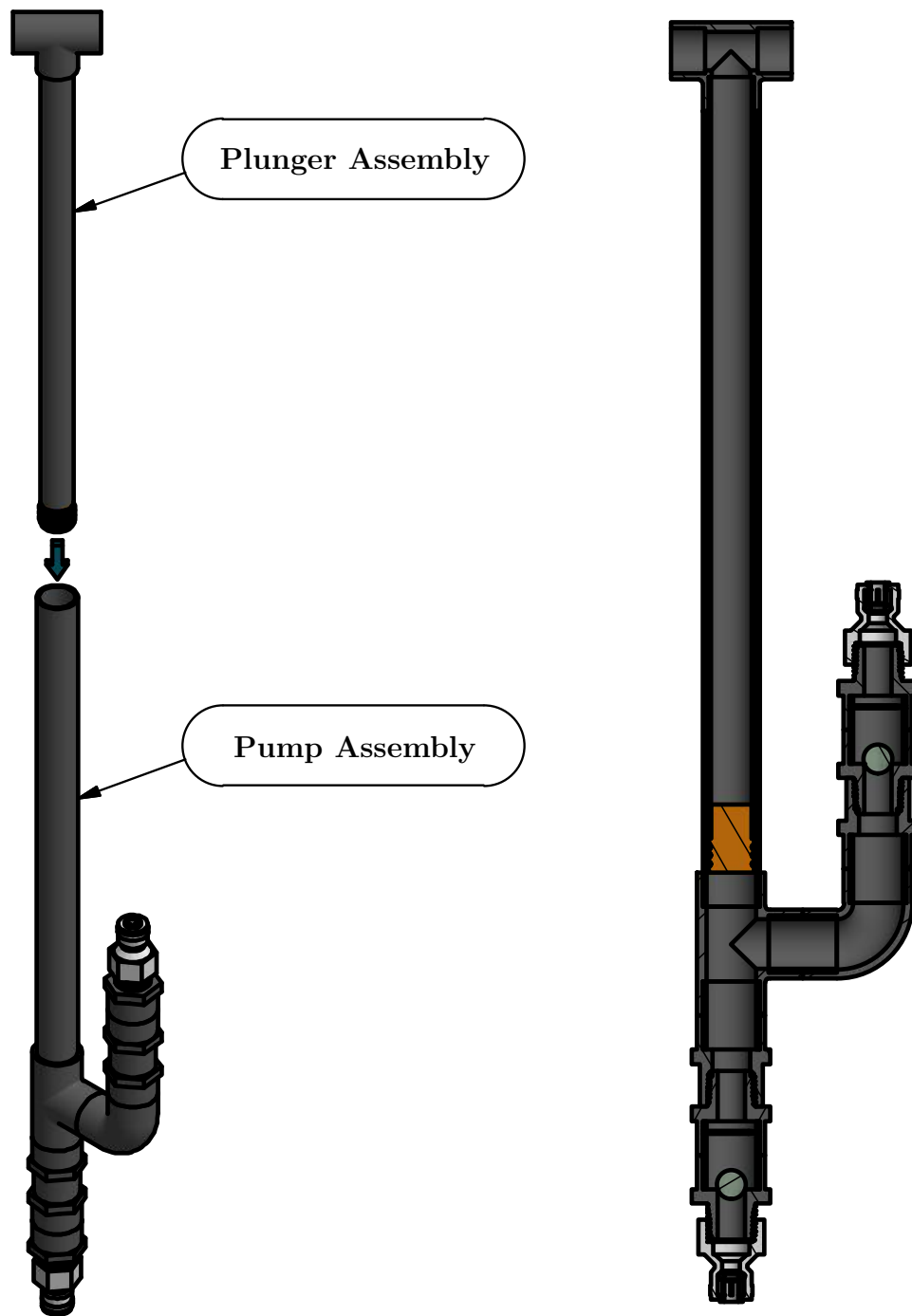

Step 18: Insert RO tubing into inlet and outlet.

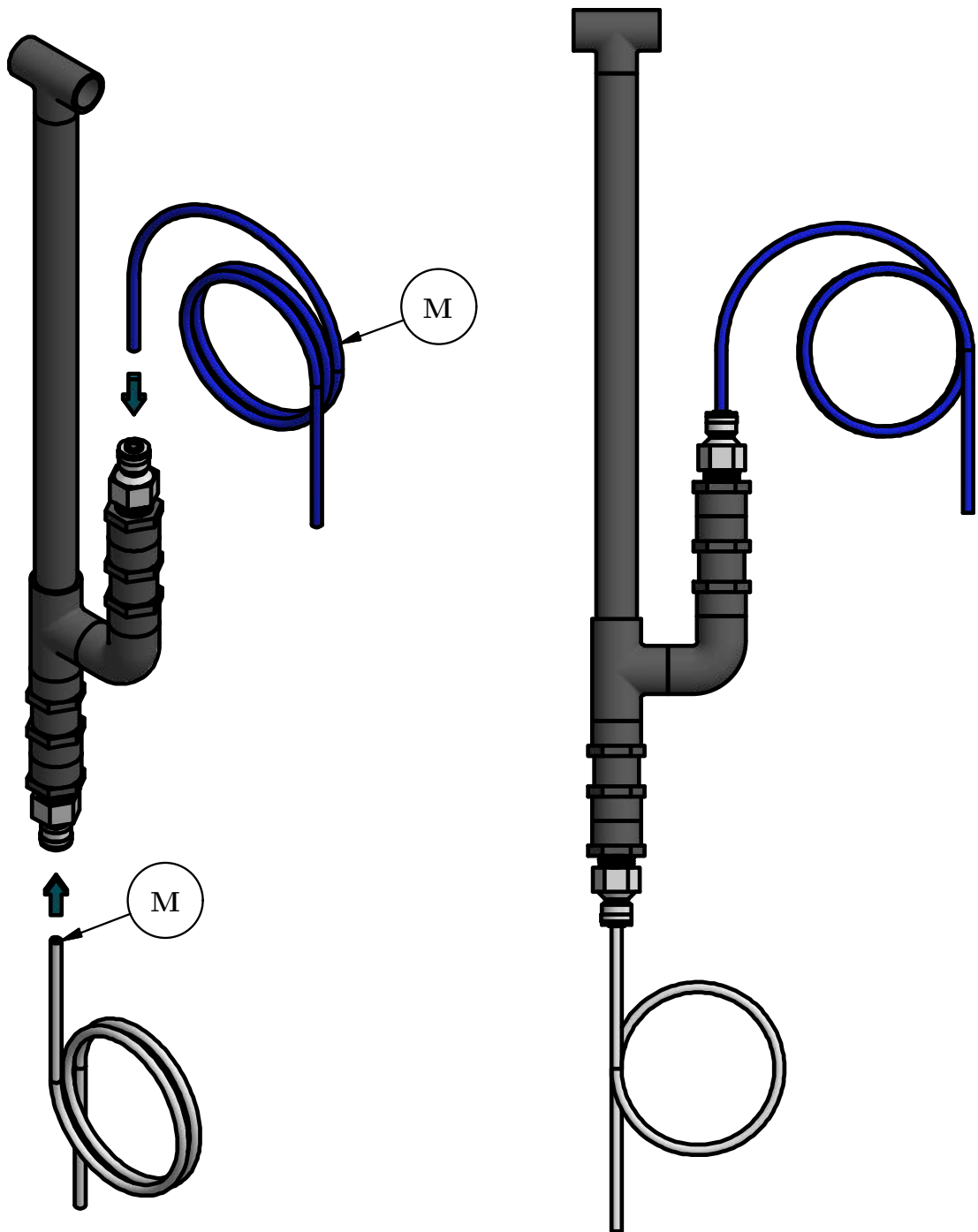

Step 19: Attach RO coupling and ultra filter to free end of outlet tube.

