

Hand-Powered Water Filter

Detail and Assembly

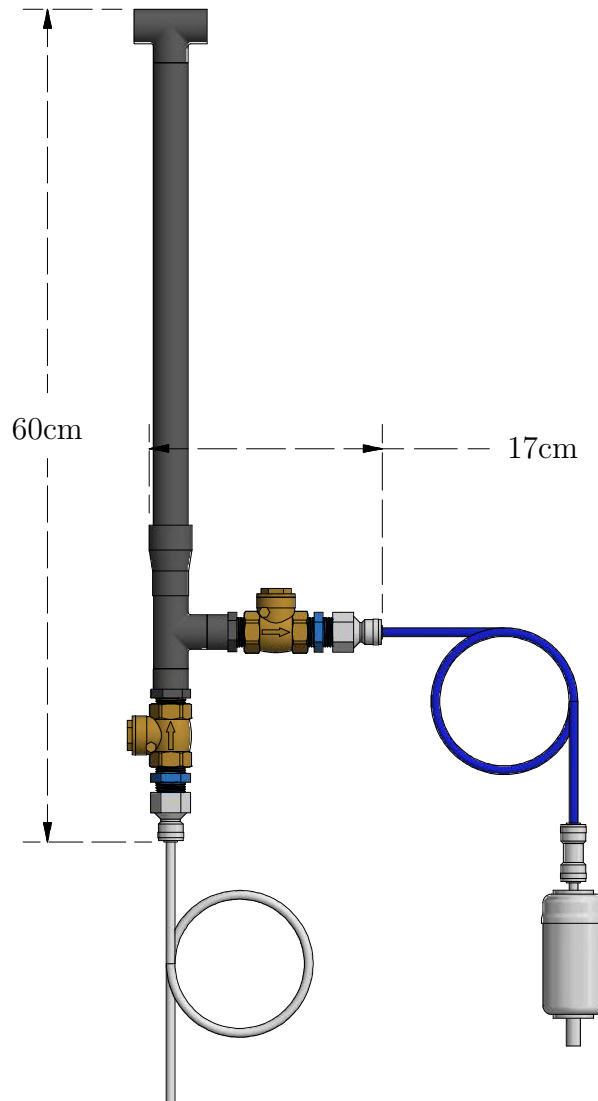

Model 5.01

Patent Pending

Last Updated January 5, 2018

Chris [REDACTED] Logston

[REDACTED]

Contents

- 1) Ultra Filter Detail 2
- 2) Check Valve Detail 3
- 3) Parts List 4
- 4) Pump Assembly 7
- 5) Plunger Assembly 13

1) Ultra Filter Detail

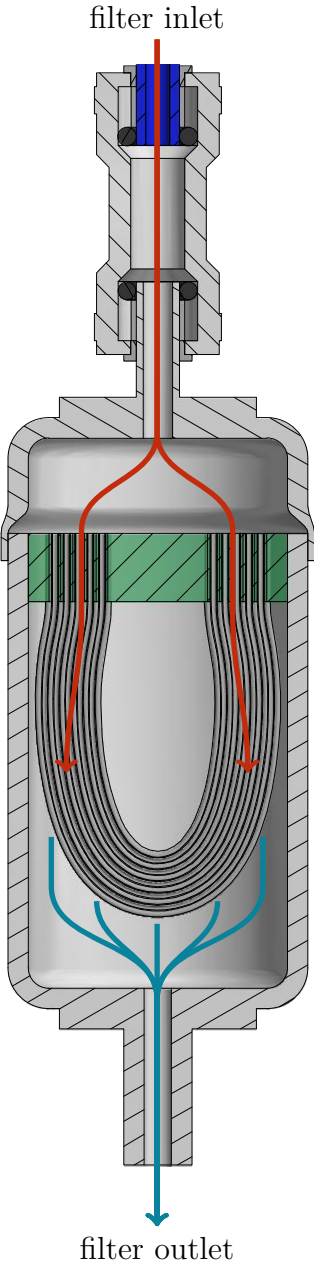

2) Check Valve Detail

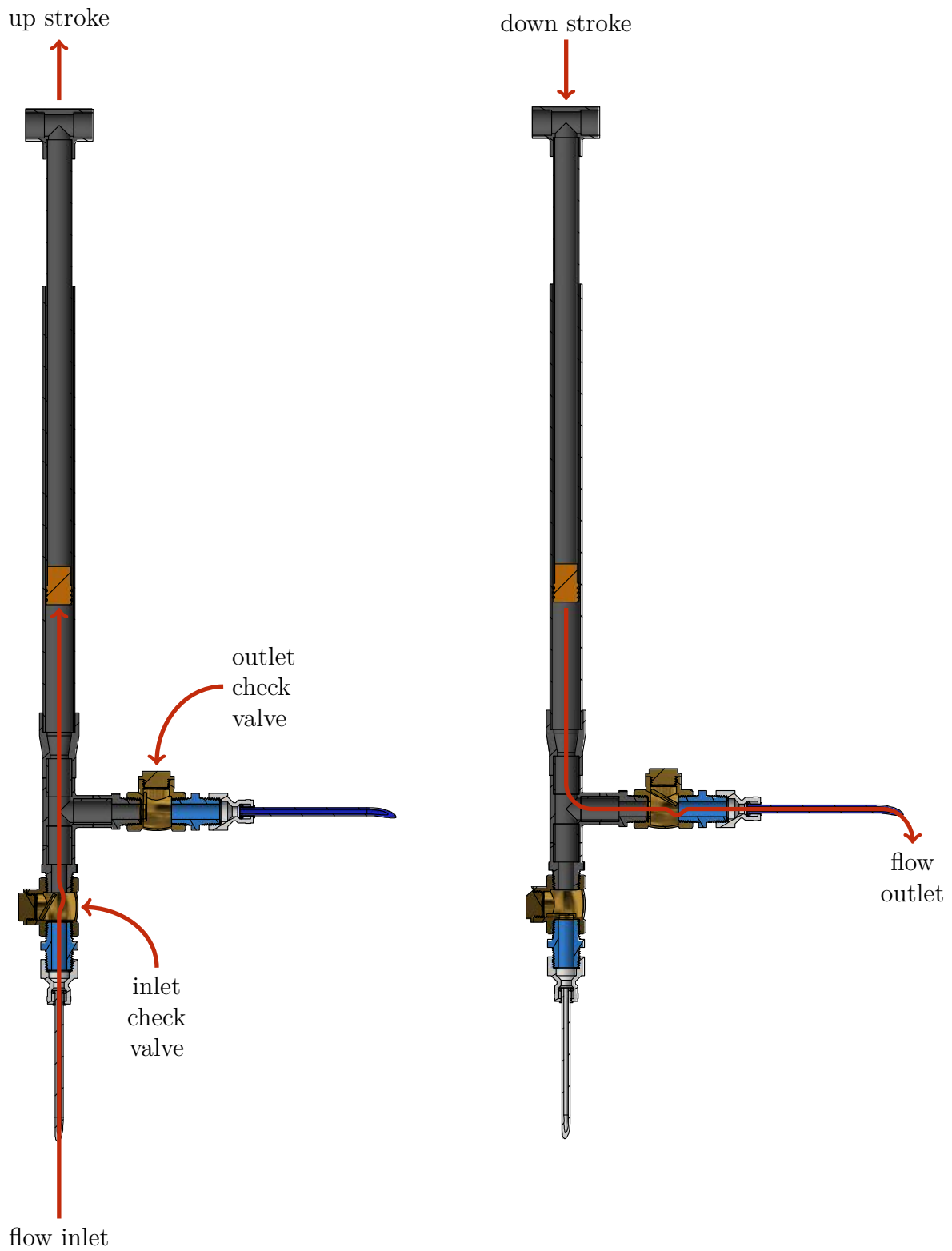

3) Parts List

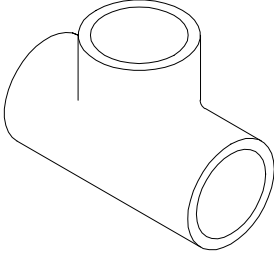
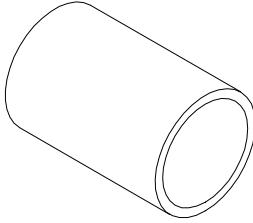
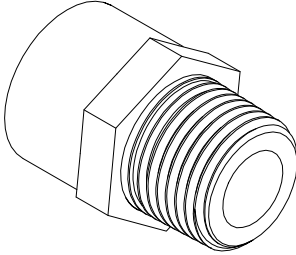
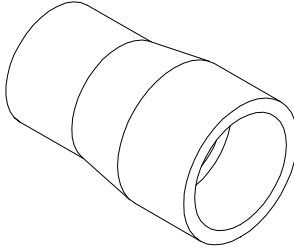
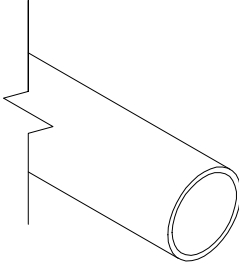
No.	Description	Image	QTY	PPU	TOT
A	PVC Tee, 20 mm plane female × 20 mm plane female × 20 mm plane female		2	₹8	₹16
B	PVC Pipe Piece, 20 mm diameter, 3 cm long		3	₹1	₹3
C	PVC Adapter, 20 mm plane female × 1/2" threaded male		2	₹8	₹16
D	PVC Reducing Coupler, 20 mm plane female × 25 mm plane female		1	₹8	₹8
E	PVC Pipe Piece, 25 mm diameter, 35 cm long		1	₹10	₹10

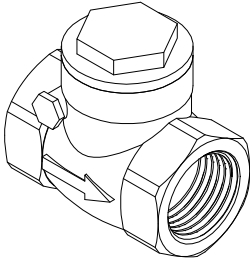
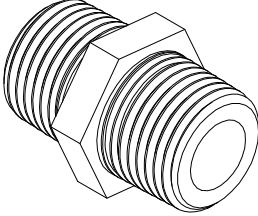
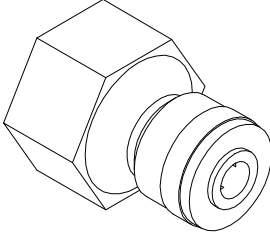
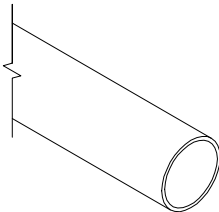
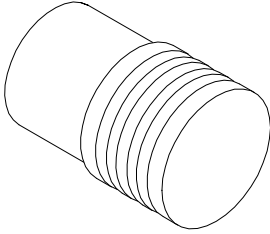
No.	Description	Image	QTY	PPU	TOT
F	Brass Check Valve 1/2" threaded female × 1/2" threaded female		2	₹110	₹220
G	PVC Nipple 1/2" threaded male × 1/2" threaded male		2	₹8	₹16
H	Quick Connect Fitting 1/2" threaded female × 1/4" quick connect female		2	₹45	₹90
I	PVC Pipe Piece 20 mm diameter, 35 cm long		1	₹10	₹10
J	PLA Chamber Plug		1	₹20	₹20

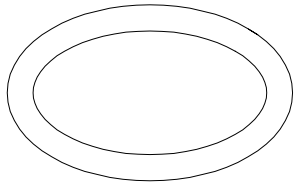
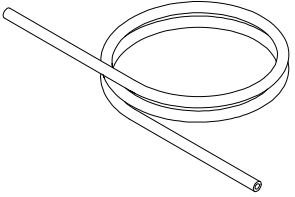
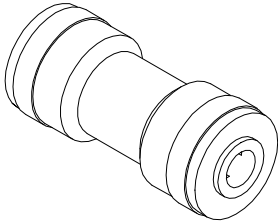
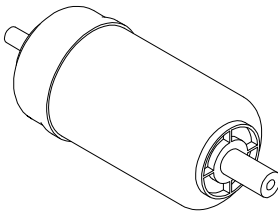
No.	Description	Image	QTY	PPU	TOT
K	Plug O-ring		3	₹5	₹15
L	Quick Connect Tubing 1/4" diameter, 50 cm long		2	₹7	₹14
M	Quick Connect Coupler 1/4" quick connect female × 1/4" quick connect female		1	₹30	₹30
N	Ultrafilter 1/4" quick connect male × 3/8" quick connect male		1	₹600	₹600
Device Total:					₹1068

4) Pump Assembly

Step 01: Insert each of the 20 *mm* PVC pipe pieces into the PVC tee.

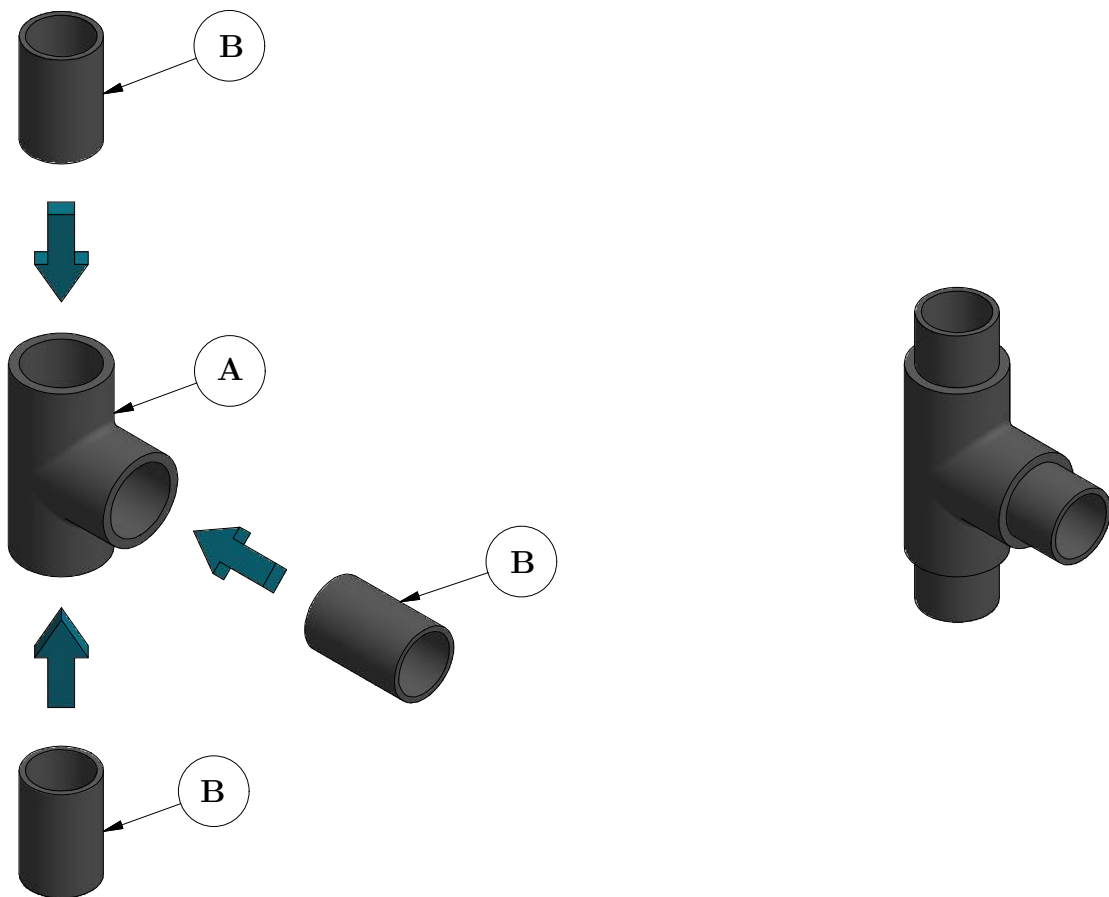

Step 02: Attach two adapters and a reducing coupler to each of the free ends.

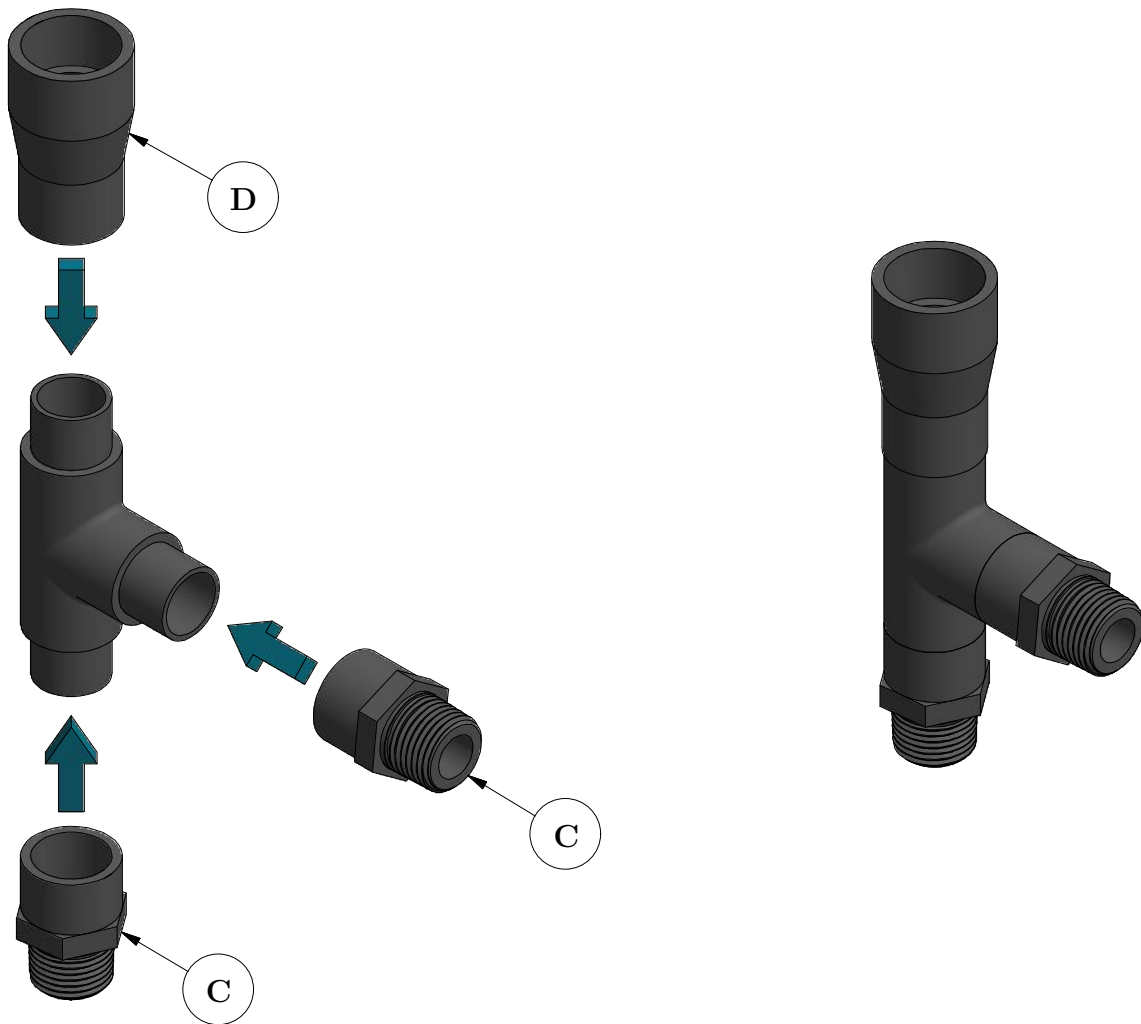

Step 03: Insert the thicker pipe piece into the reducing coupler.

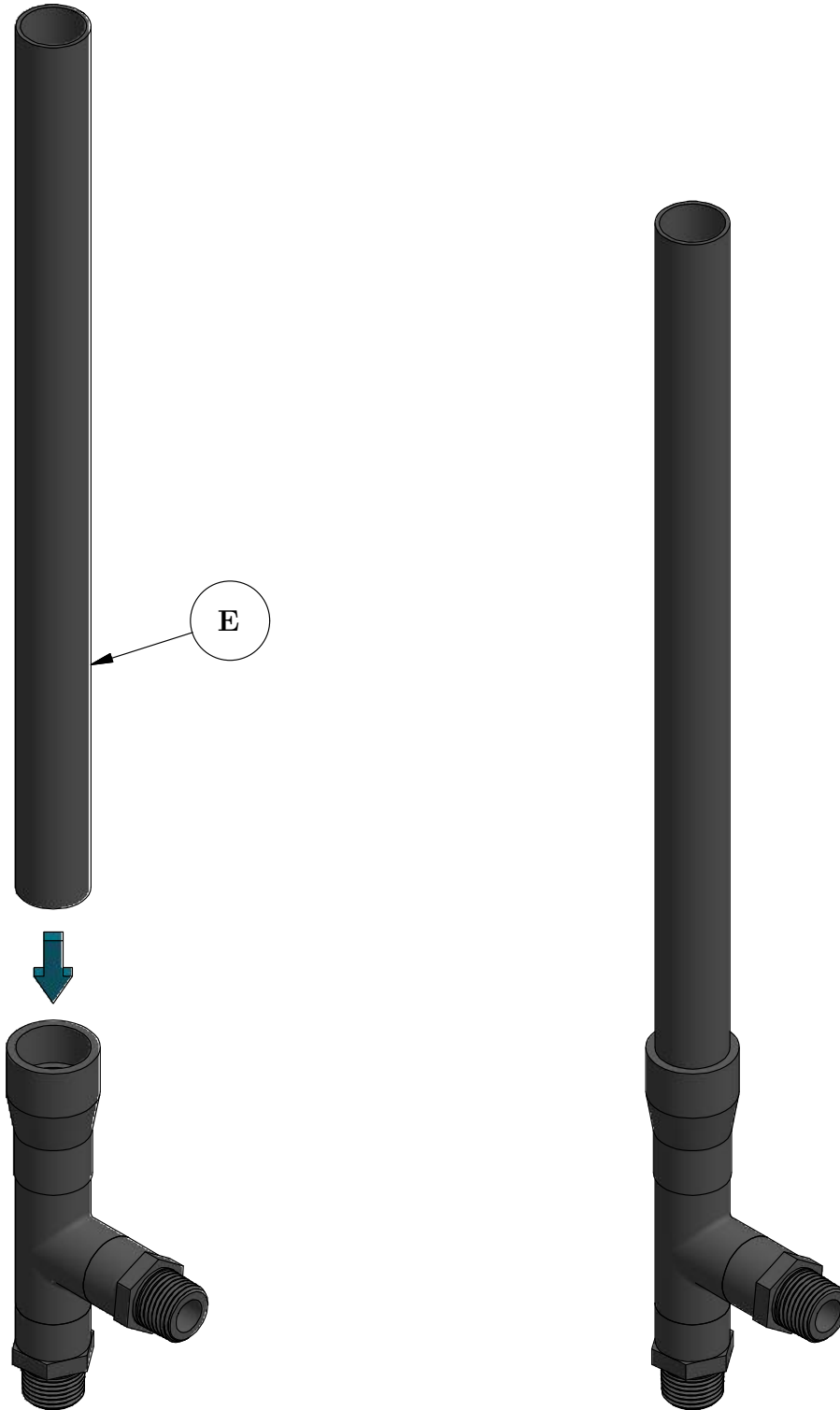

Step 04: Attach a check valve to each open adapter end.



Step 05: Insert a threaded nipple into each check valve.



Step 06: Attach a quick connect fitting to the end of each nipple.

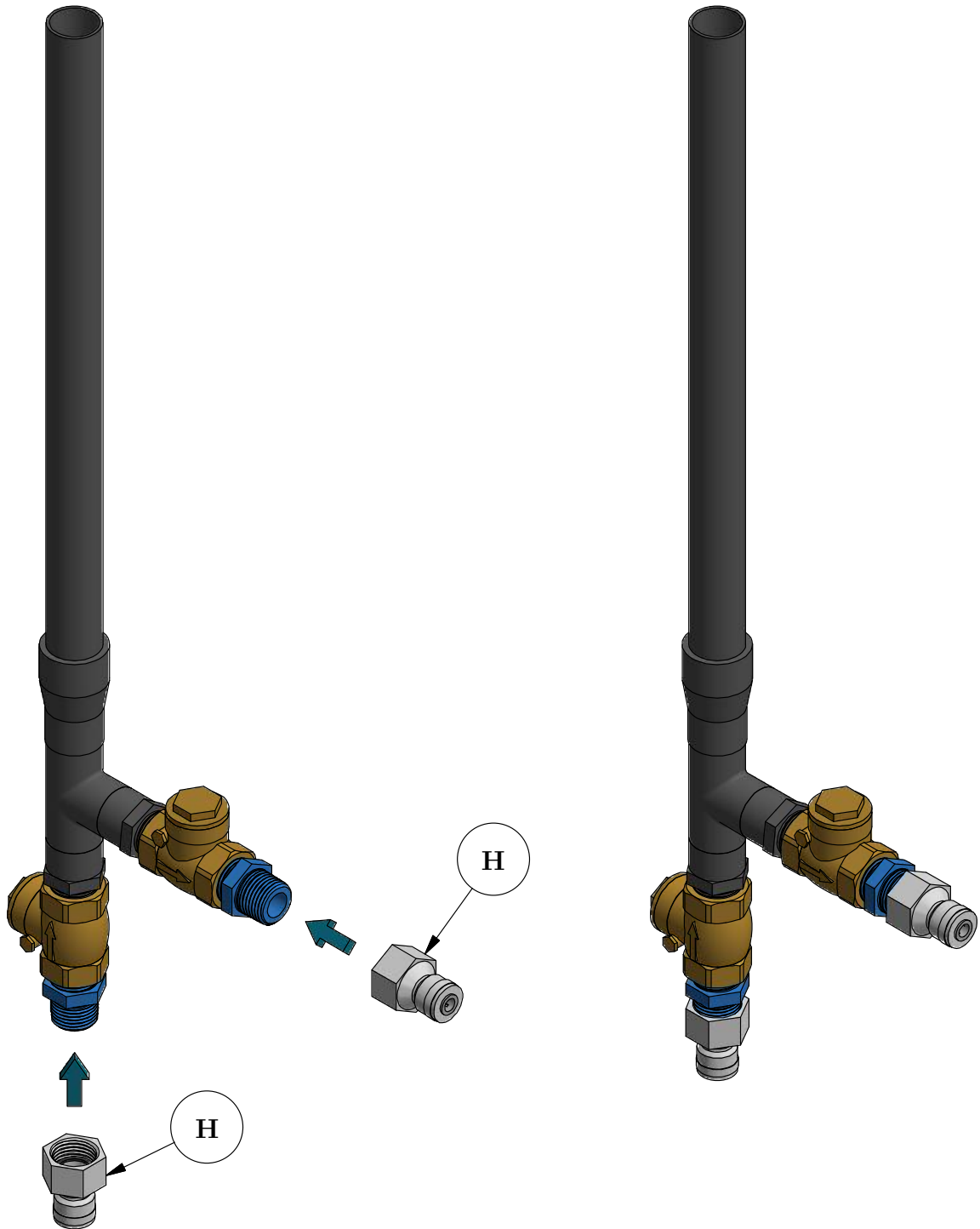

5) Plunger Assembly

Step 07: Attach the smaller tee to the smaller pipe.

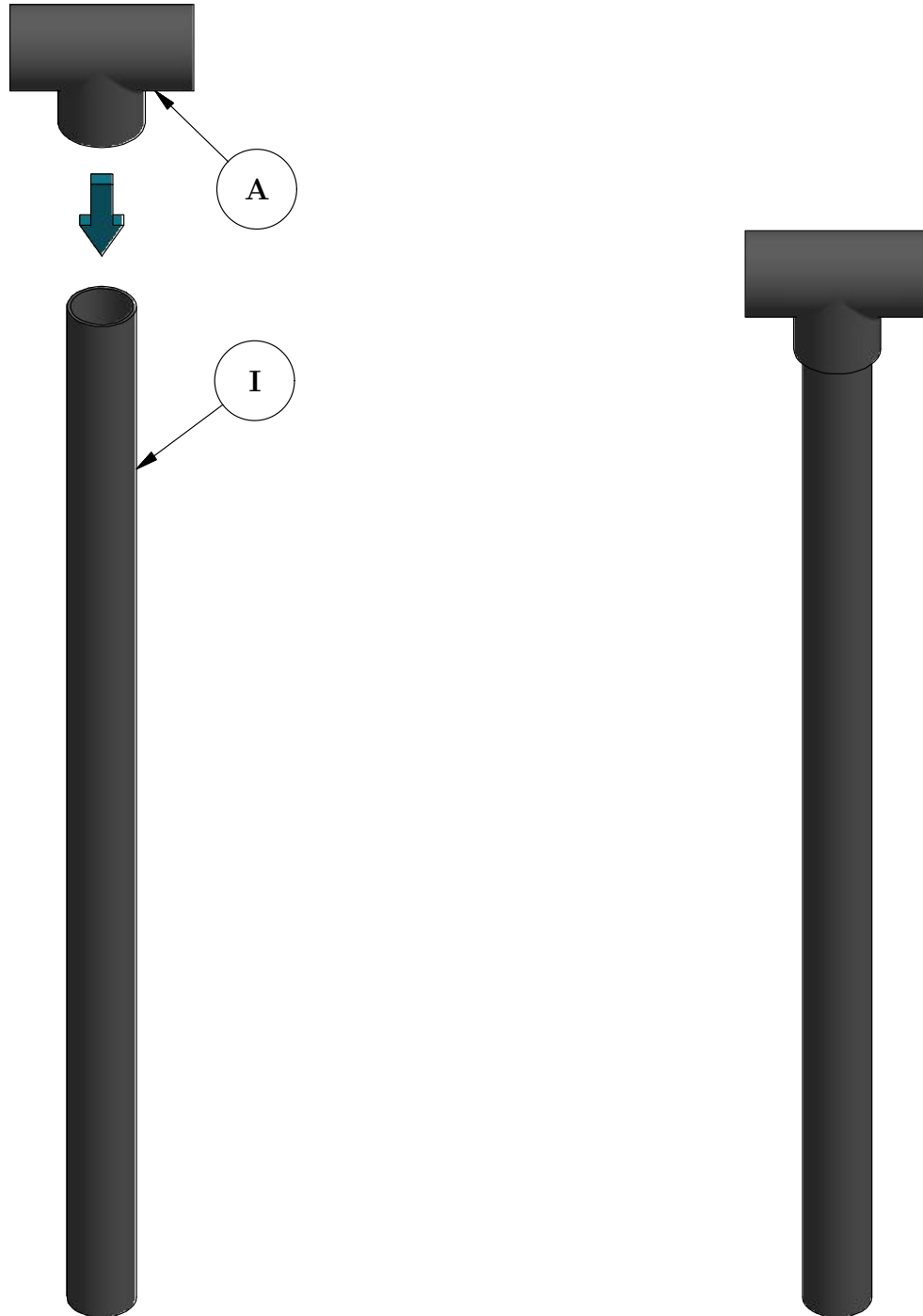

Step 08: Insert chamber plug into the other end of the smaller pipe.

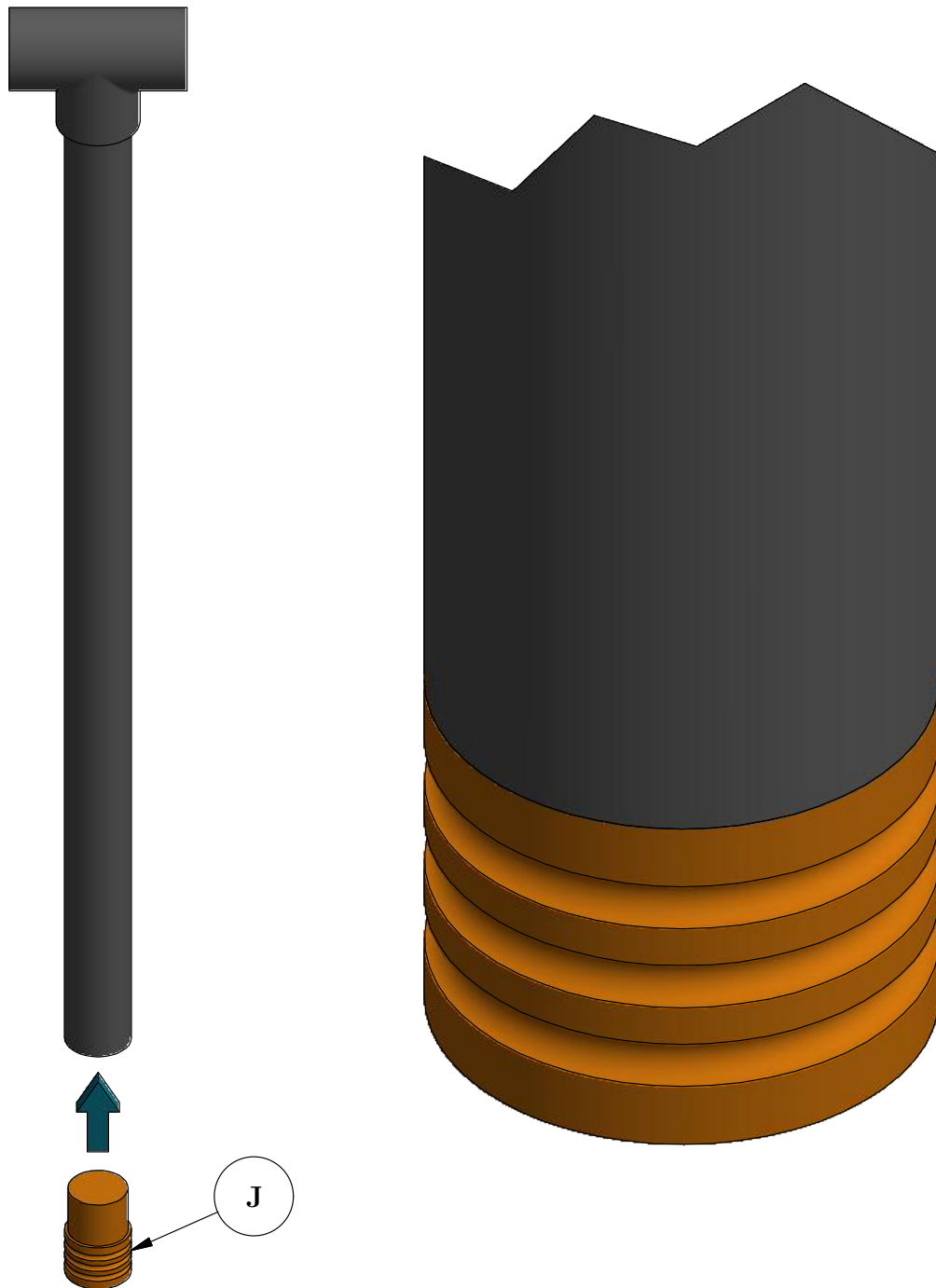

Step 09: Attach three O-rings to the plug.

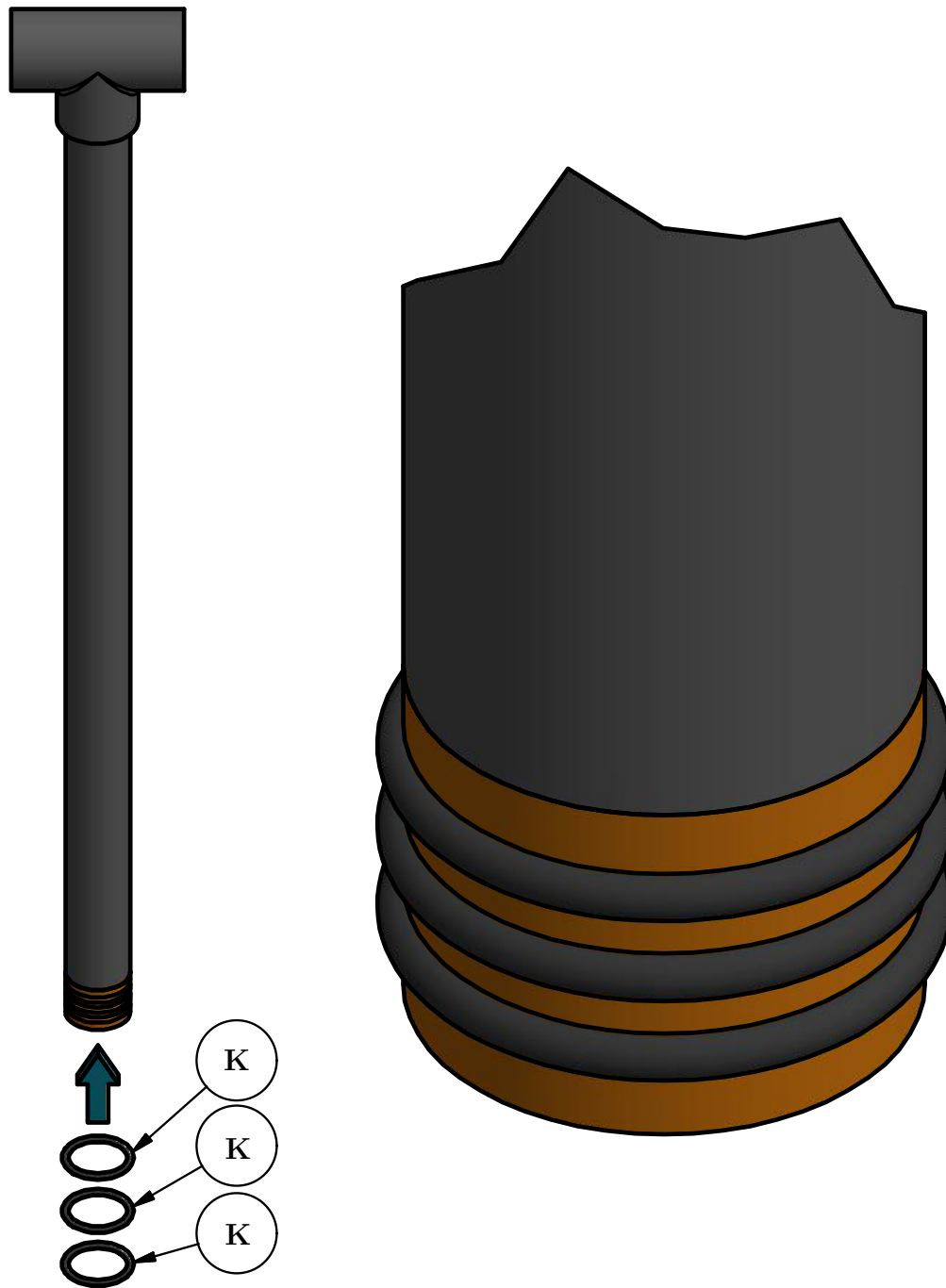

Step 10: Insert plunger assembly into pump assembly.

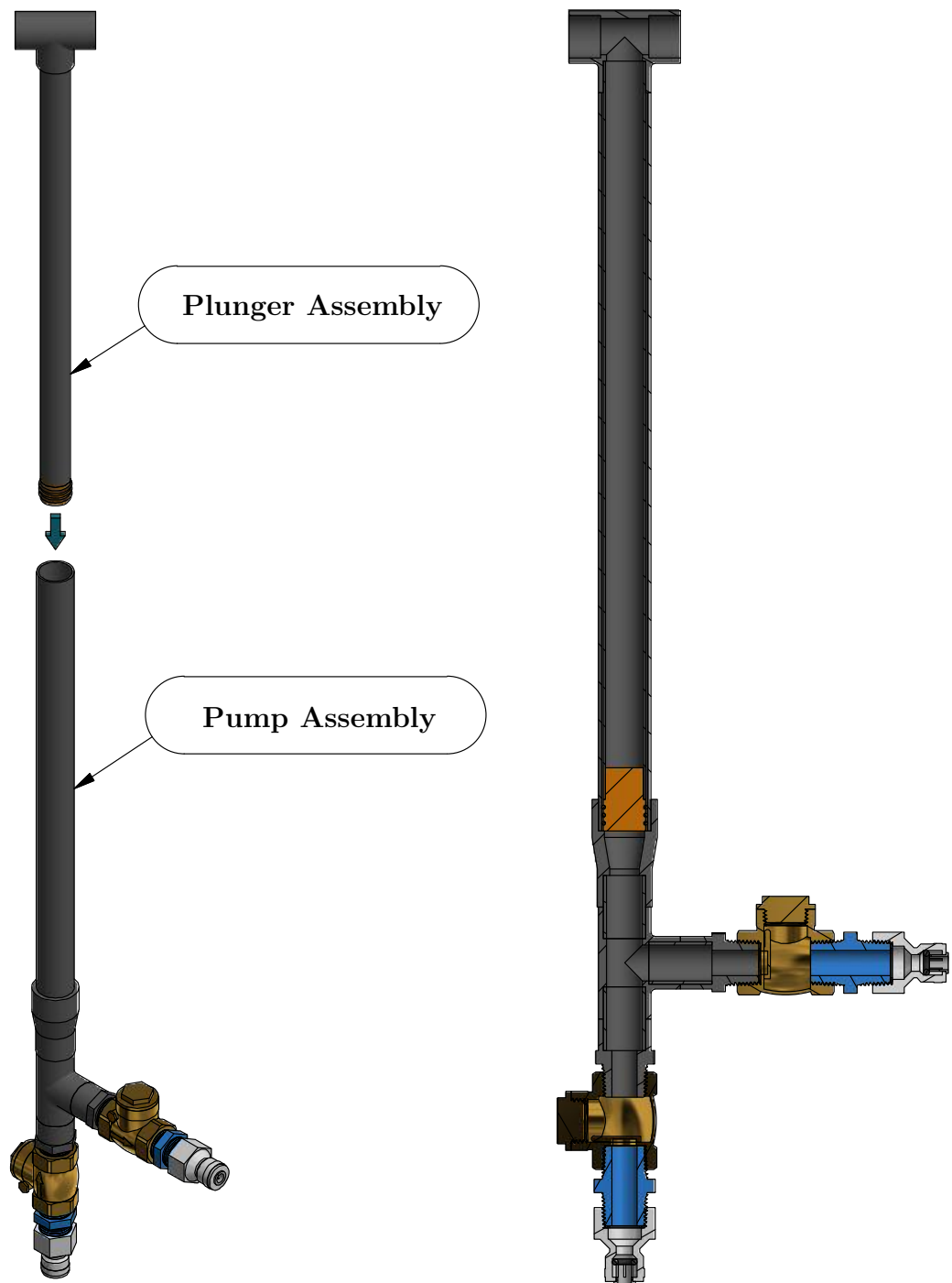

Step 11: Insert RO tubing into inlet and outlet.

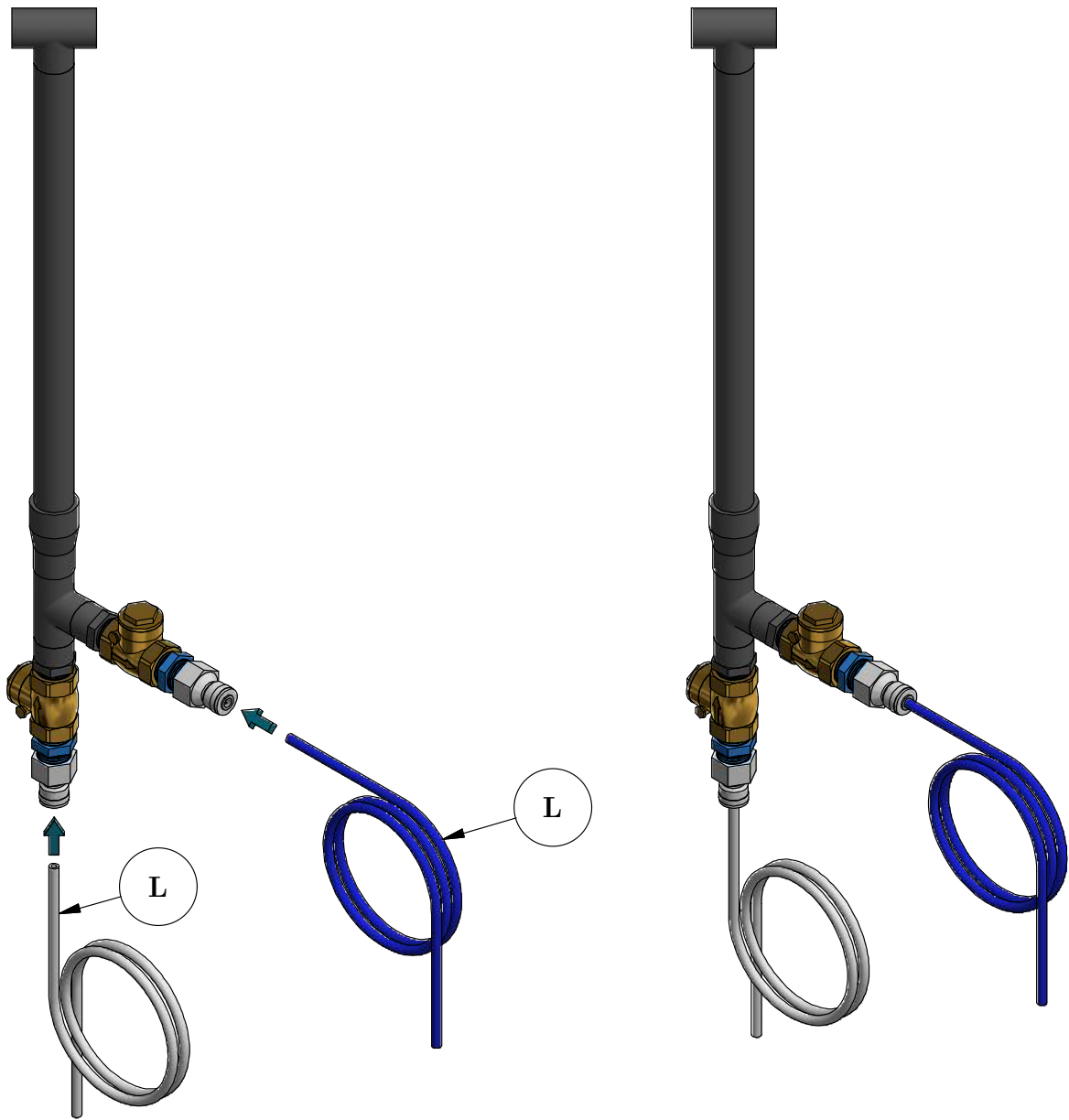

Step 12: Attach RO coupling and ultra filter to free end of outlet tube.

