

Hand-Powered Water Filter

Detail and Assembly

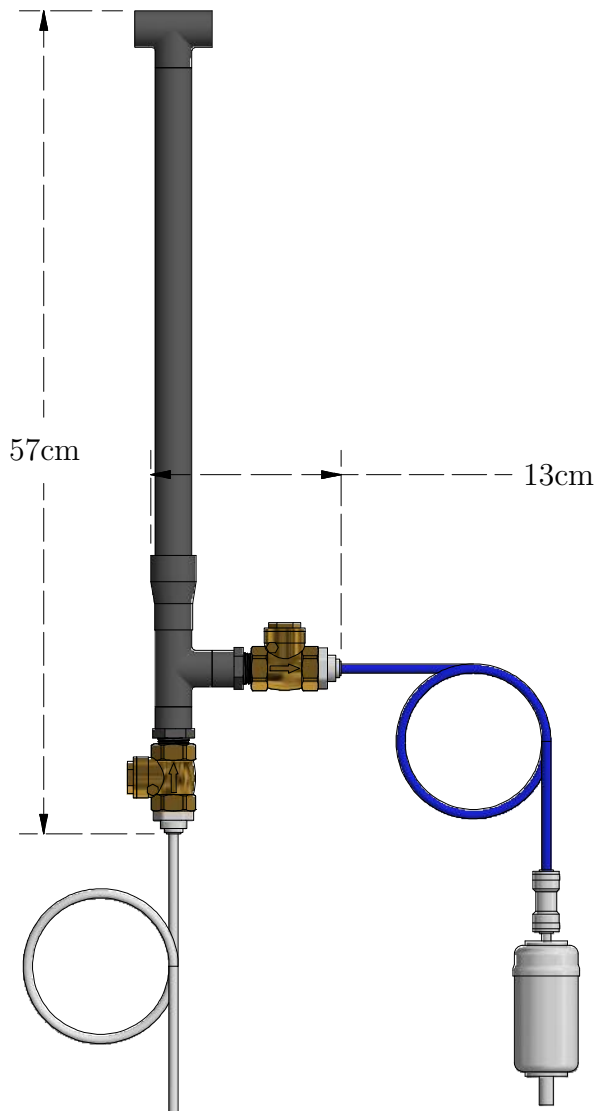

Model 5.02

Patent Pending

Last Updated January 5, 2018

Christopher Bulkley - Logston

Kaylea Brase

Contents

- 1) Ultra Filter Detail 2
- 2) Check Valve Detail 3
- 3) Parts List 4
- 4) Pump Assembly 7
- 5) Plunger Assembly 12

1) Ultra Filter Detail

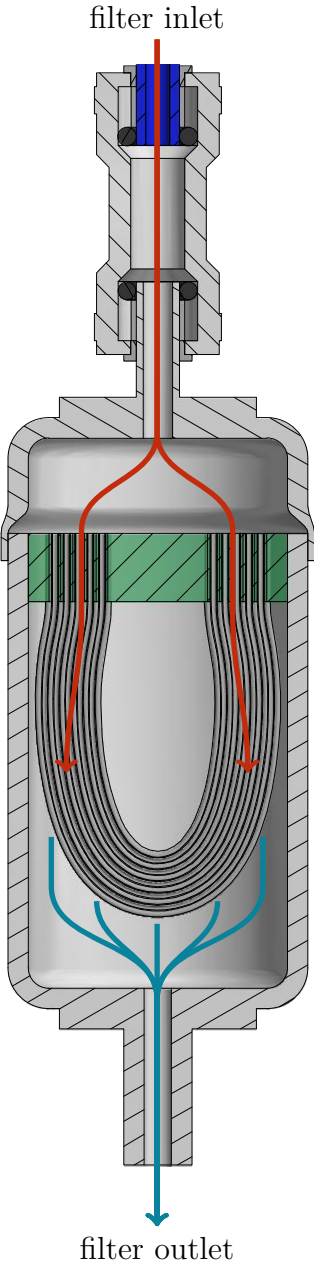

2) Check Valve Detail

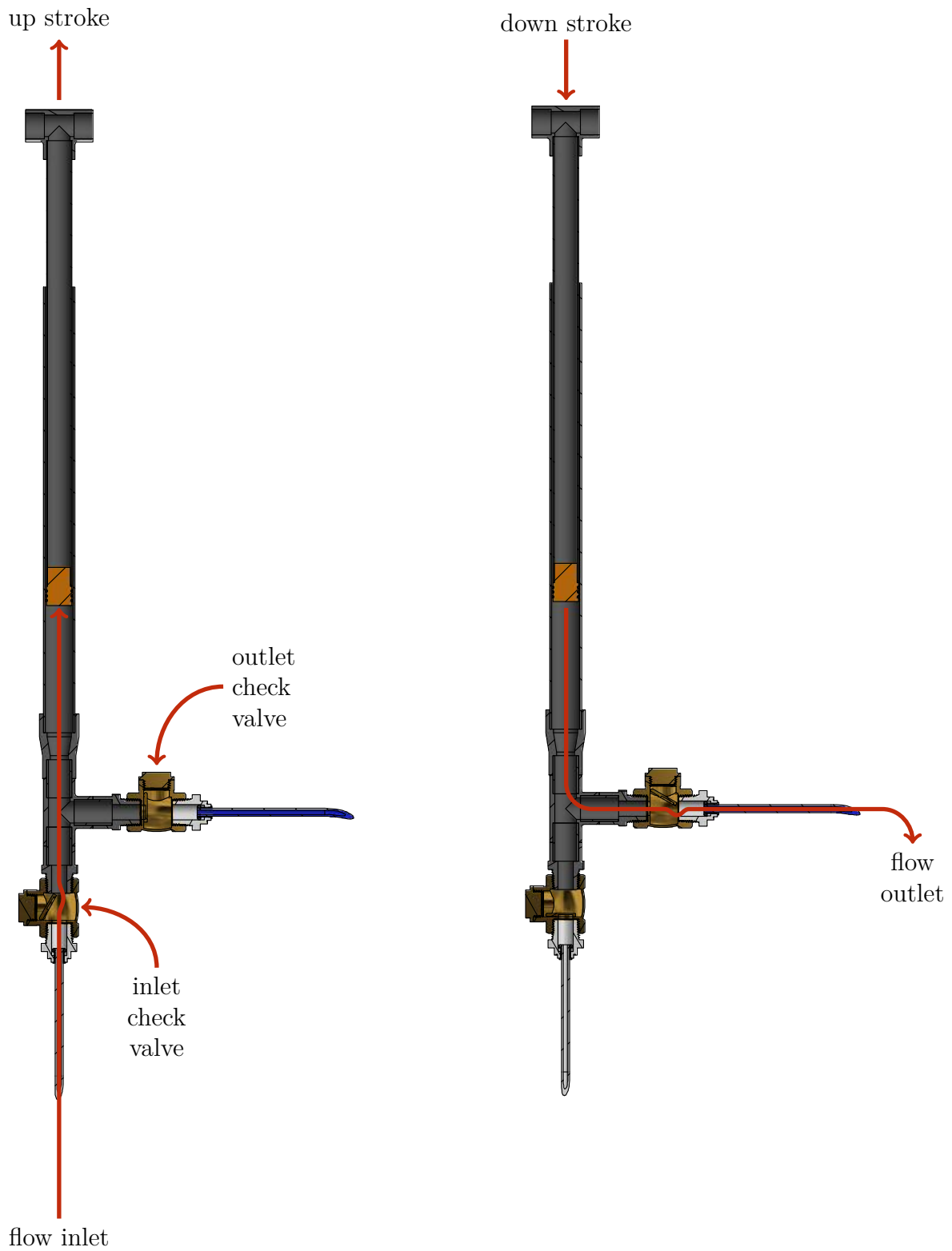

3) Parts List

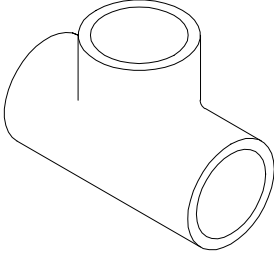
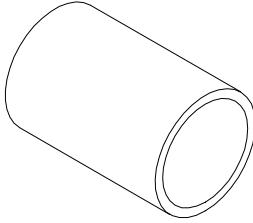
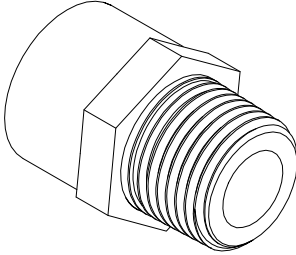
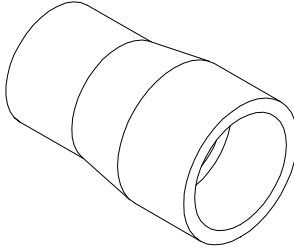
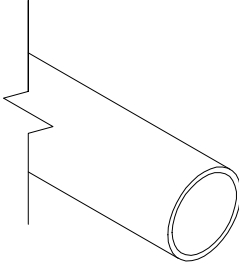
No.	Description	Image	QTY	PPU	TOT
A	PVC Tee, 20 mm plane female × 20 mm plane female × 20 mm plane female		2	₹8	₹16
B	PVC Pipe Piece, 20 mm diameter, 3 cm long		3	₹1	₹3
C	PVC Adapter, 20 mm plane female × 1/2" threaded male		2	₹8	₹16
D	PVC Reducing Coupler, 20 mm plane female × 25 mm plane female		1	₹8	₹8
E	PVC Pipe Piece, 25 mm diameter, 35 cm long		1	₹10	₹10

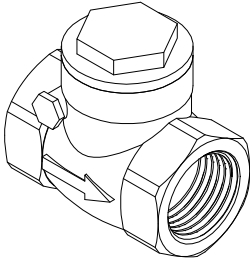
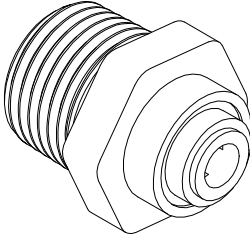
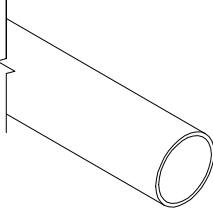
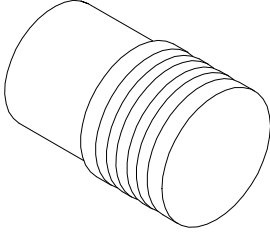
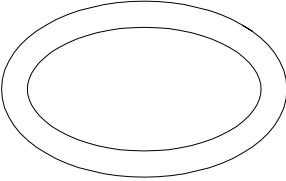
No.	Description	Image	QTY	PPU	TOT
F	Brass Check Valve 1/2" threaded female × 1/2" threaded female		2	₹110	₹220
G	PVC Adapter 1/2" threaded male × 1/4" quick connect female		2	₹45	₹90
H	PVC Pipe Piece 20 mm diameter, 35 cm long		1	₹10	₹10
I	PLA Chamber Plug		1	₹20	₹20
J	Plug O-ring		3	₹5	₹15

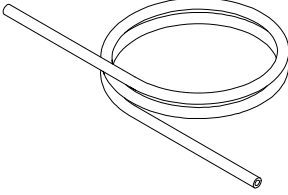
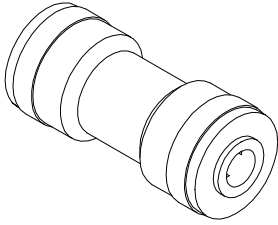
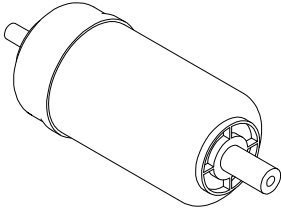
No.	Description	Image	QTY	PPU	TOT
K	Quick Connect Tubing 1/4" diameter, 50 cm long		2	₹7	₹14
L	Quick Connect Coupler 1/4" quick connect female × 1/4" quick connect female		1	₹30	₹30
M	Ultrafilter 1/4" quick connect male × 3/8" quick connect male		1	₹600	₹600
Device Total:					₹1052

4) Pump Assembly

Step 01: Insert each of the 20 *mm* PVC pipe pieces into the PVC tee.

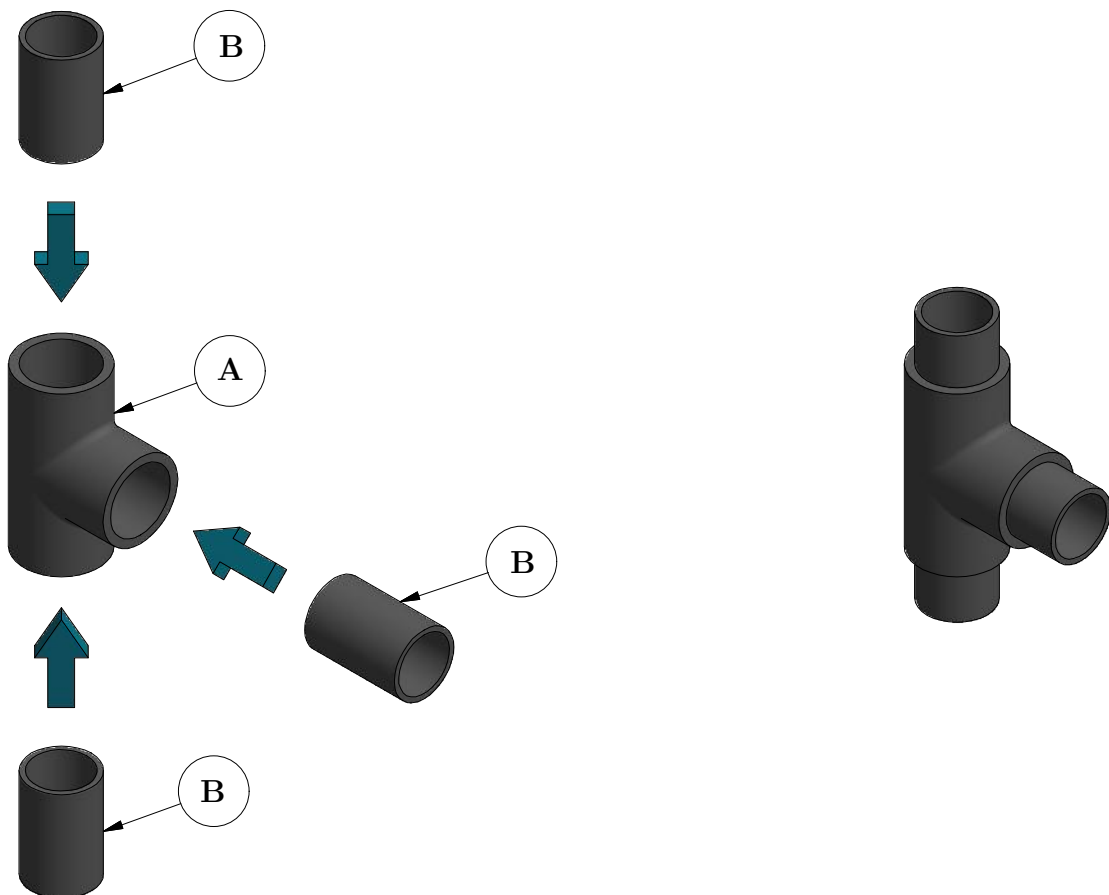

Step 02: Attach the two adapters and the reducing coupler to each of the free ends.

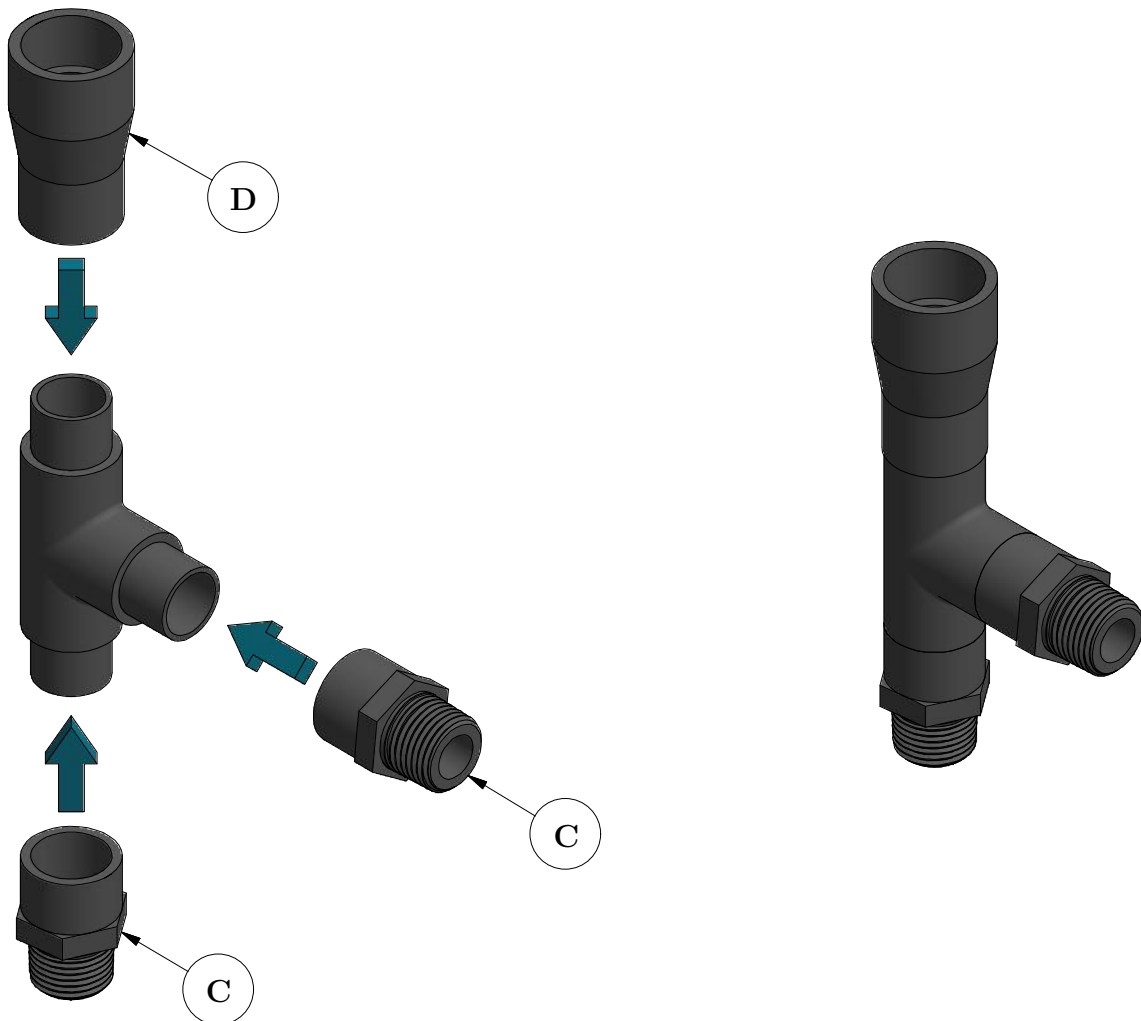

Step 03: Insert the thicker pipe piece into the reducing coupler.

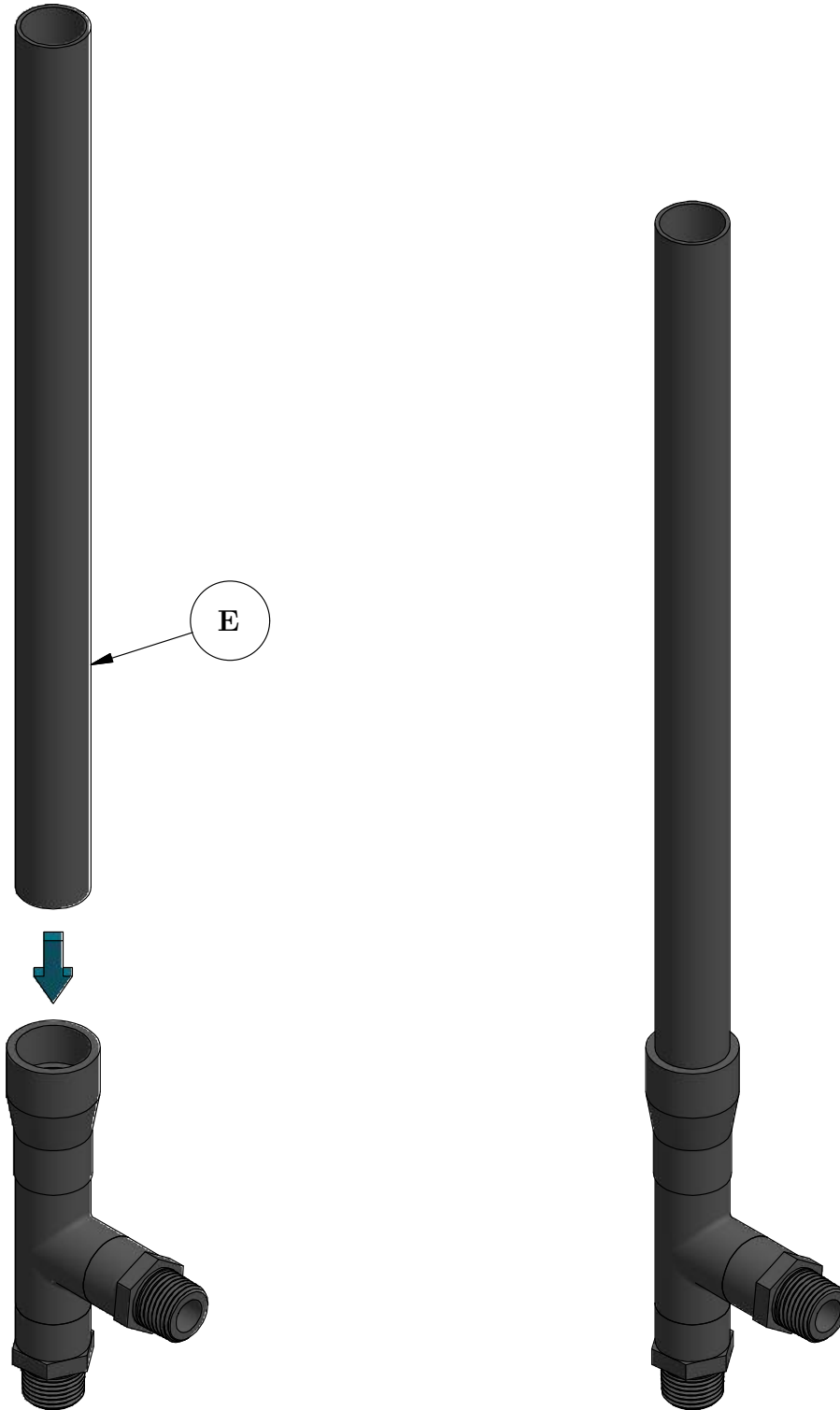

Step 04: Attach a check valve to each open adapter end.



Step 05: Insert a PVC threaded/quick connect adapter into each each valve.

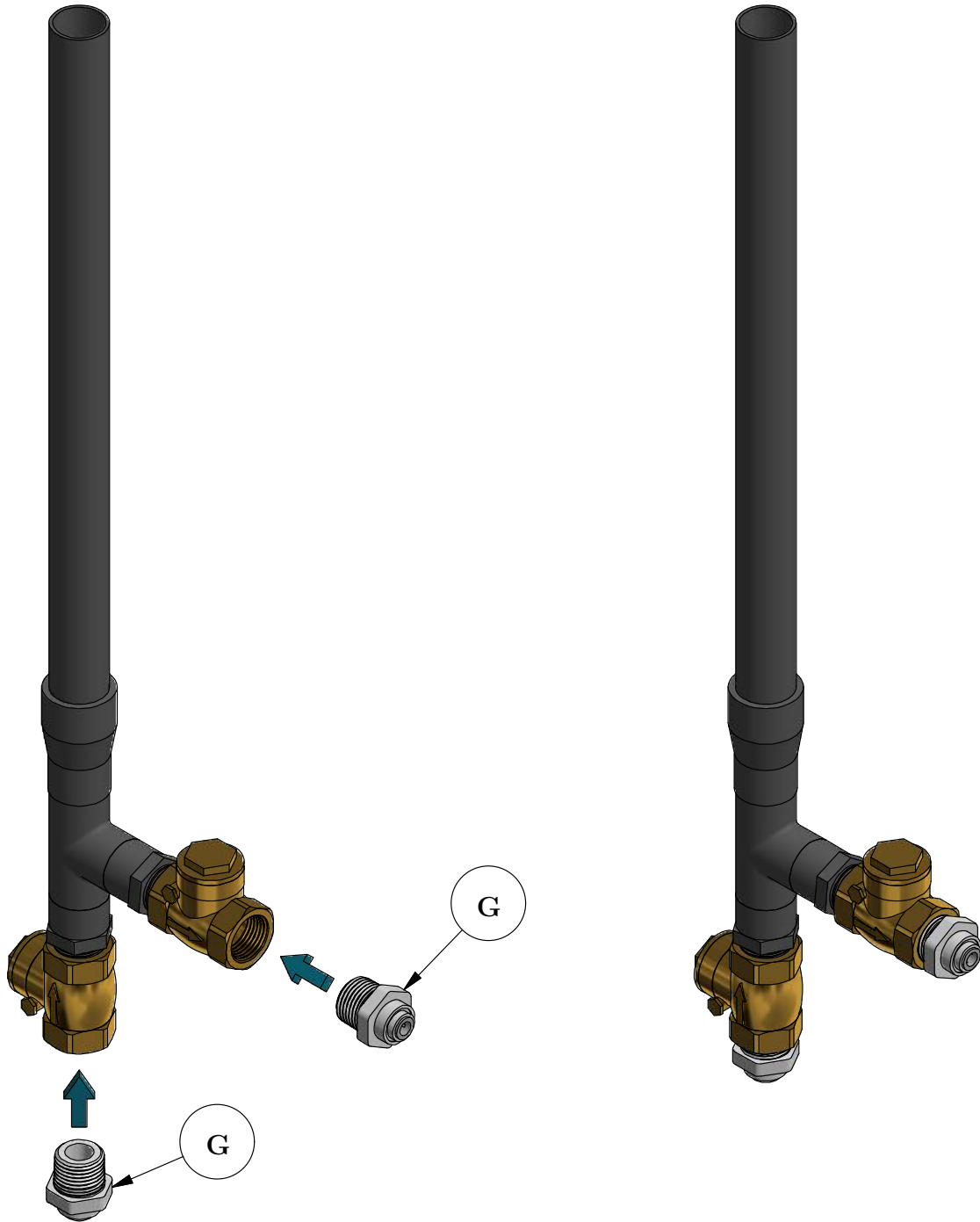

5) Plunger Assembly

Step 06: Attach the smaller tee to the smaller pipe.

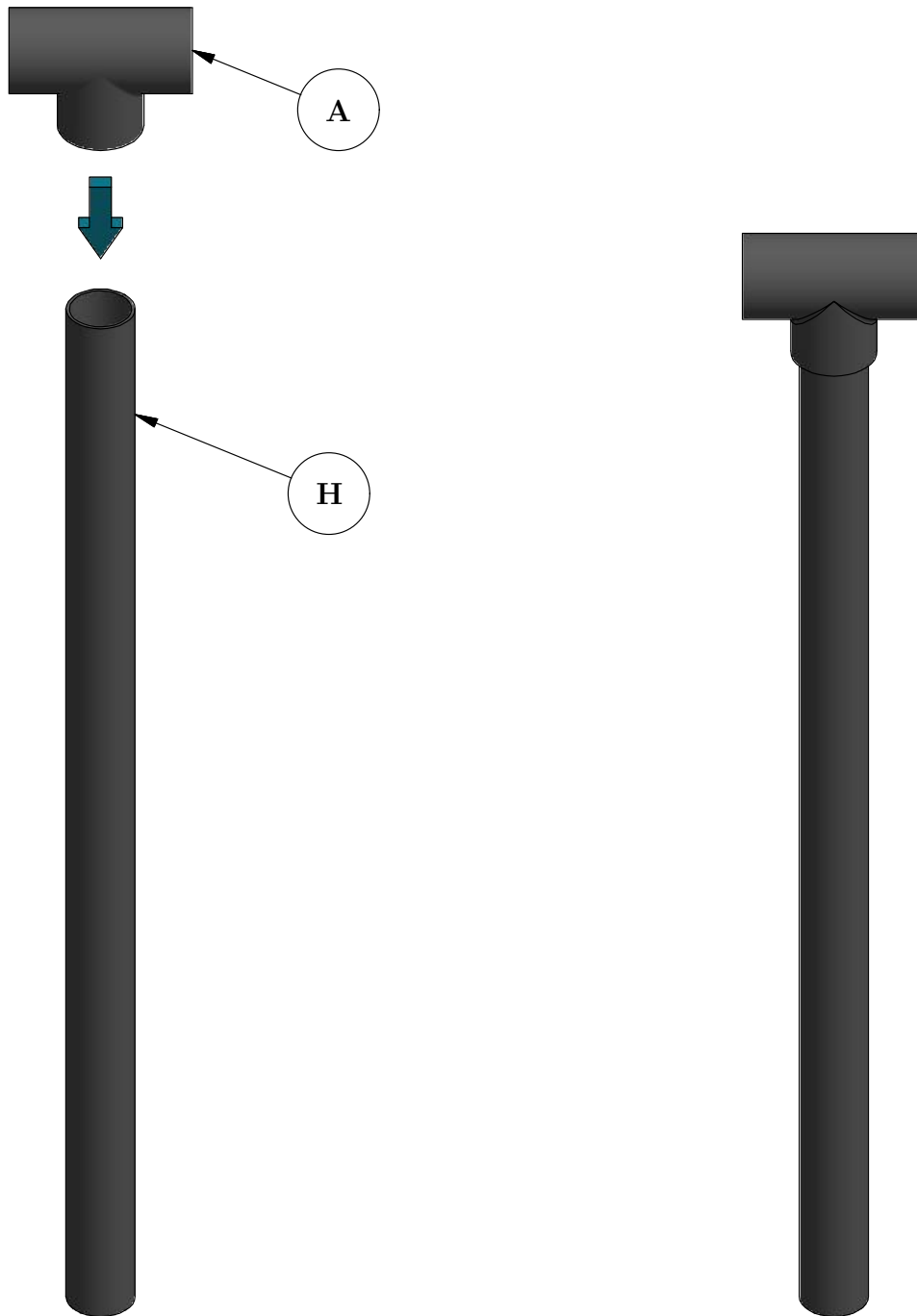

Step 07: Insert the chamber plug into the other end of the smaller pipe.

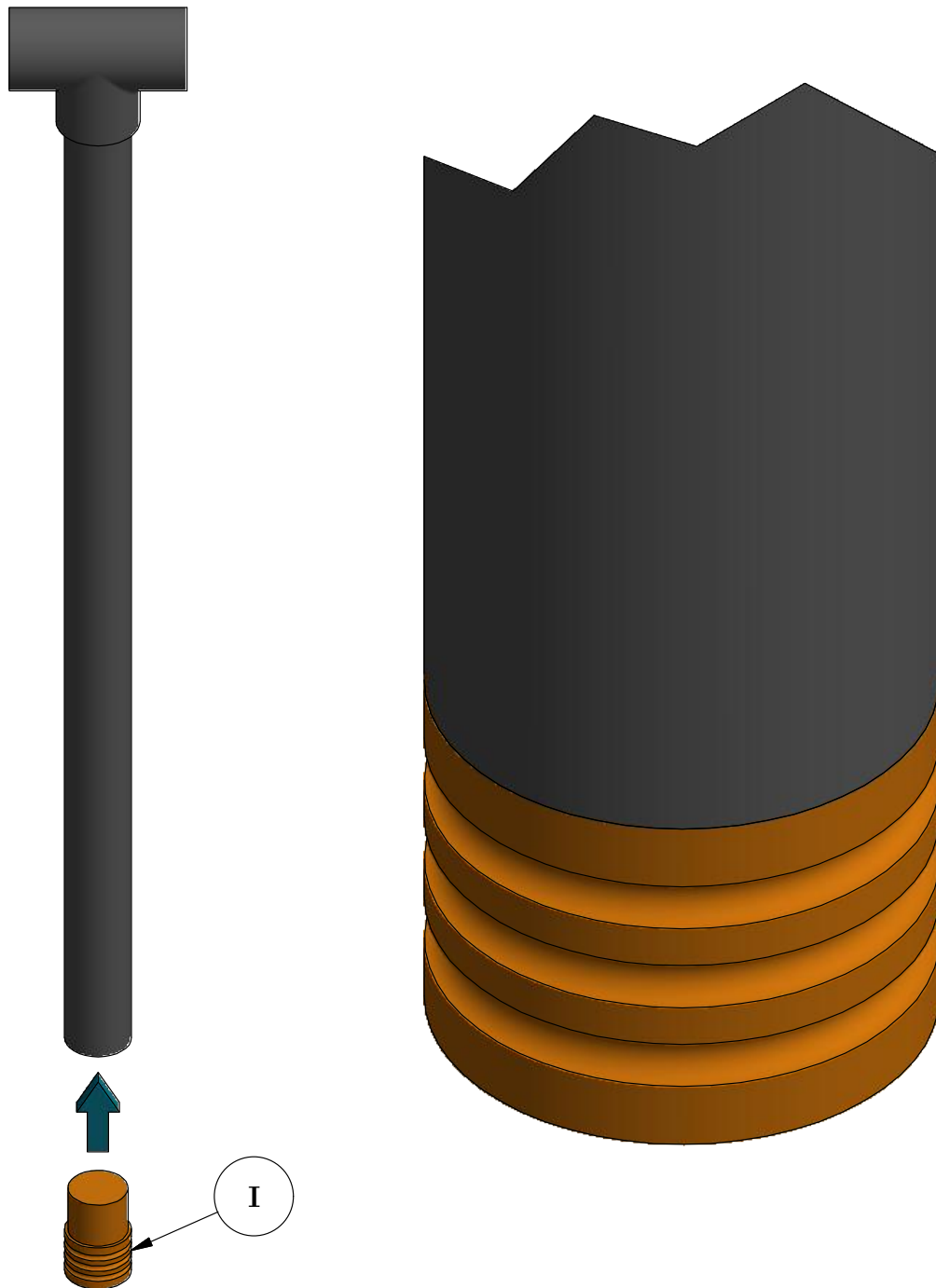

Step 08: Attach the three O-rings to the plug.

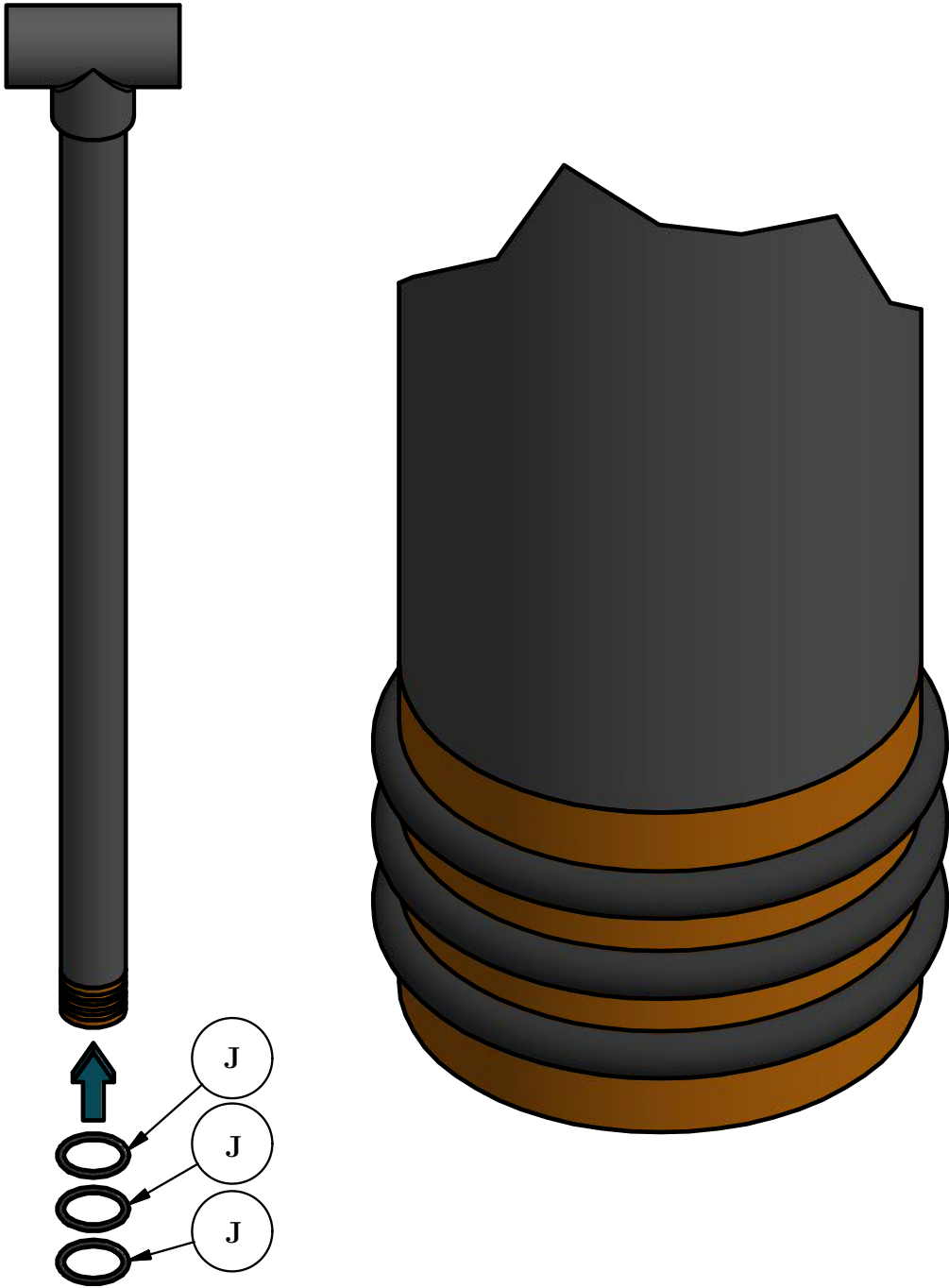

Step 09: Insert the plunger assembly into the pump assembly.

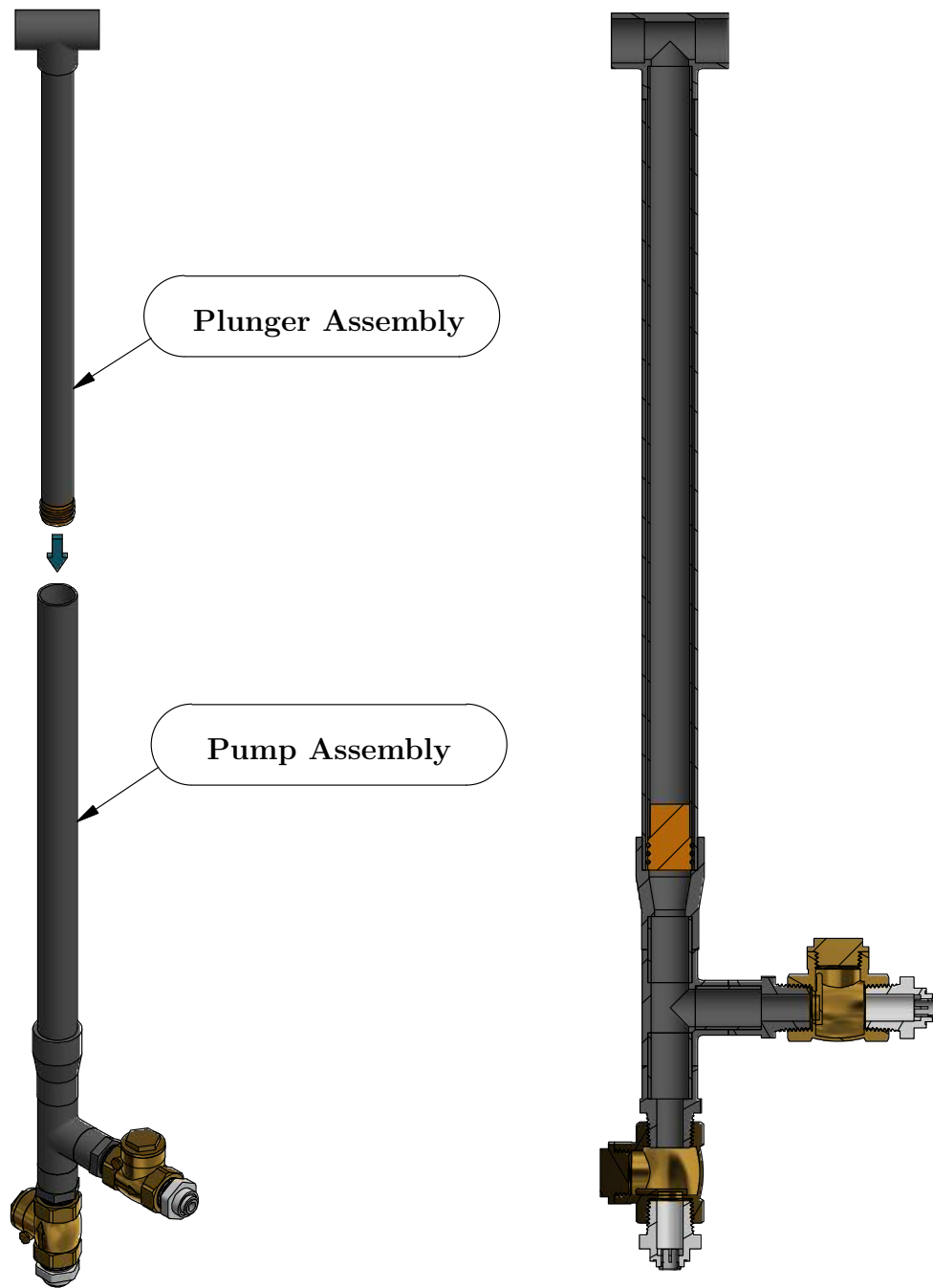

Step 10: Insert the RO tubing into the inlet and outlet adapters.

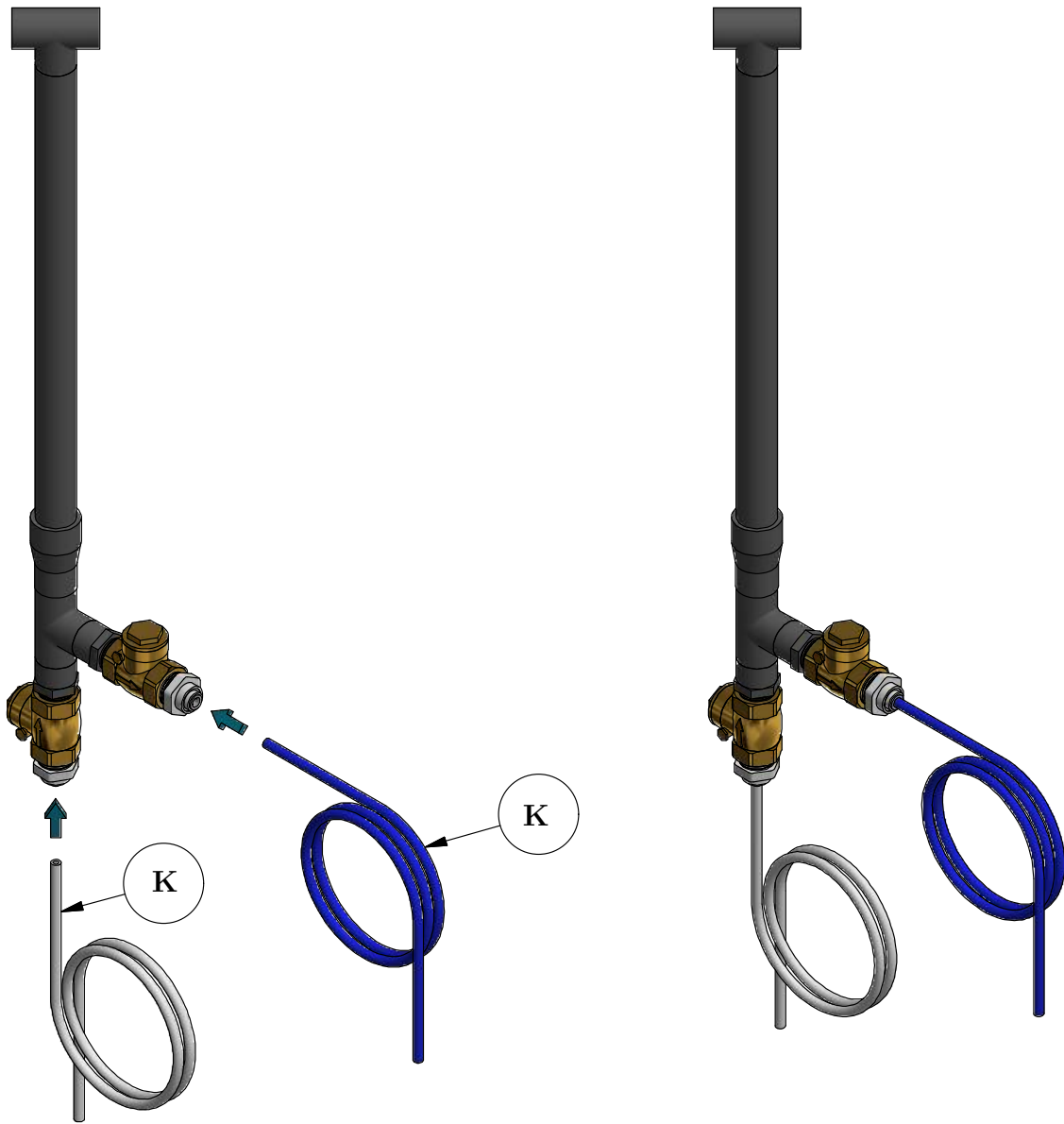

Step 11: Attach the RO coupling and ultra filter to the free end of the outlet tube.

